

K374

Fitting Kit

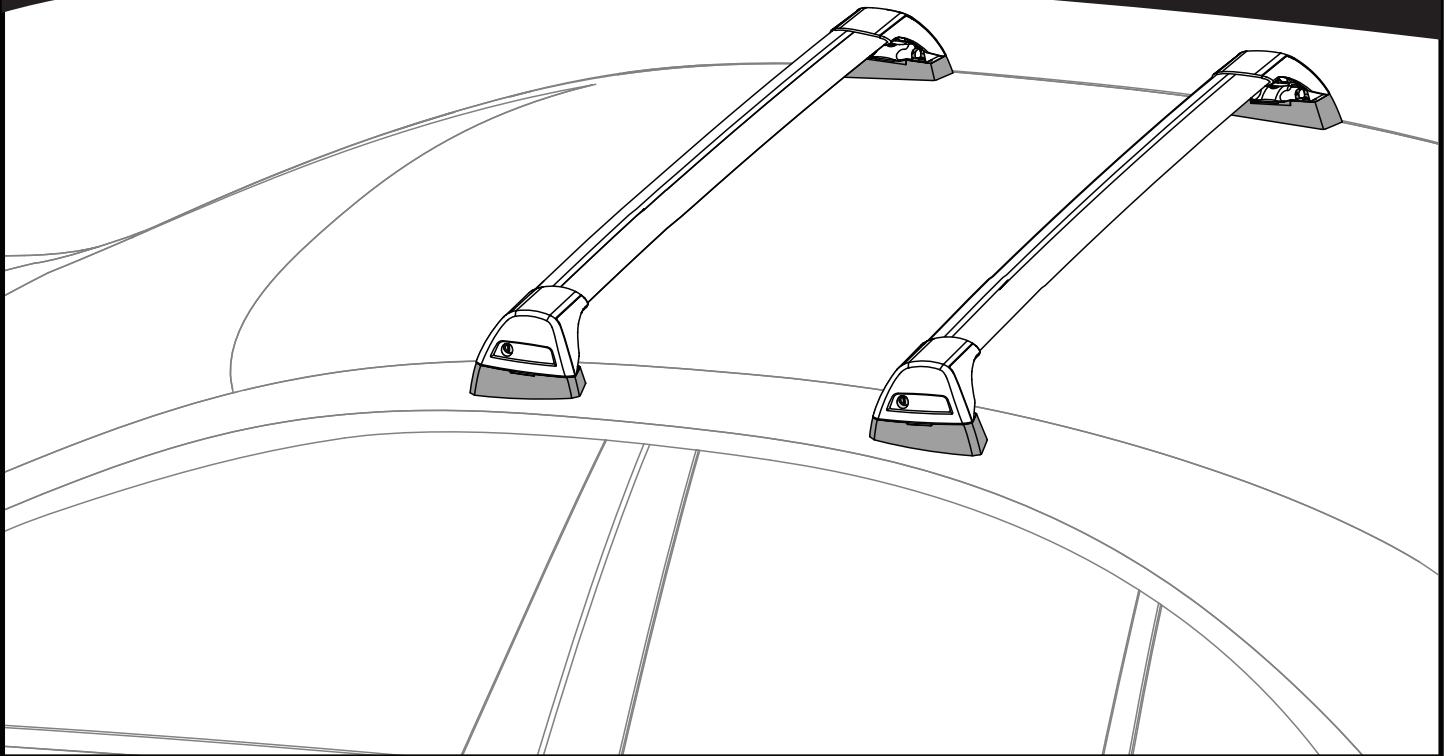

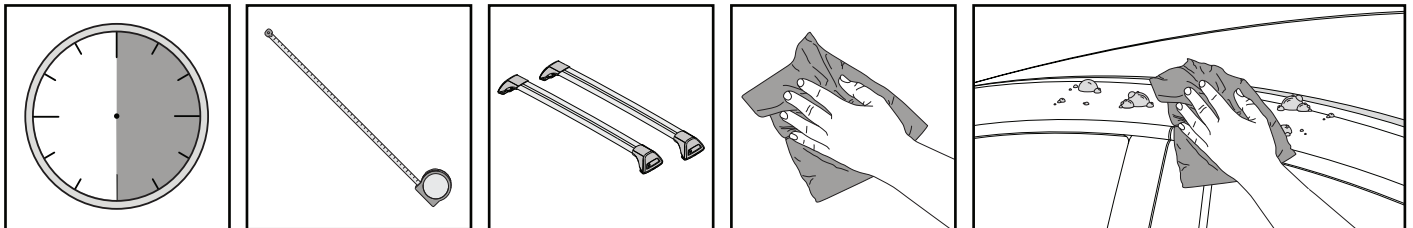



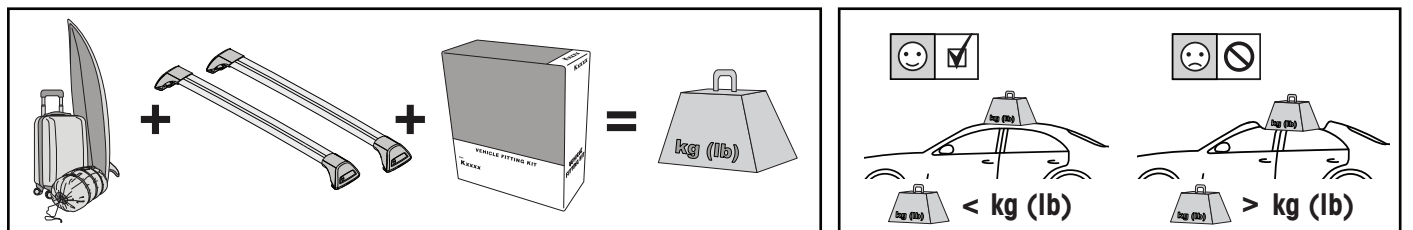

**REQUIRED • ERFORDERLICH • REQUERIDOS • OBLIGATOIRE • NØDVENDIG • NECESSÁRIO • ОБЯЗАТЕЛЬНО • OBLIGATORIO
POTRZEBY • NEVYHNUTELNÉ • NEVYHNUTNÉ • NODIG • NØDVÄNDIG • PÅKRÆVET • ПОТРІБНА • EDellyTETÄÄN**

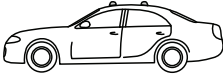

**MAXIMUM kg (lb) • MAXIMUM kg • MÁXIMO kg • MAXIMUM kg • MAKSIMALT kg • MÁXIMO kg
МАКСИМУМ кг • MASSIMO kg • MAKSIMALNEJ kg • MAXIMÁLNÍ kg • MAXIMÁLNE kg
MAXIMUM kg • MAXIMAL kg • MAKSIMAL kg • МАКСИМАЛЬНА kg • ENIMMÄISMÄÄRÄ kg**



		F 	T 	P 	HD 
BMW 3 Series E46 Compact, 3dr Hatch 00-04	EU		75 kg (165 lb)		75 kg (165 lb)
BMW 3 Series E46 Compact, 3dr Hatch 01-04	AU, NZ, ZA		75 kg (165 lb)		75 kg (165 lb)
BMW 3 Series E46, 4dr Sedan 99-04	EU, ZA		75 kg (165 lb)		75 kg (165 lb)
BMW 3 Series E46, 4dr Sedan Jul 99-May 04	NZ		75 kg (165 lb)		75 kg (165 lb)
BMW 3 Series E46, 4dr Sedan Oct 99-May 04	AU		75 kg (165 lb)		75 kg (165 lb)

CONTENTS • INHALT • CONTENIDO • CONTENU • INNHOLD • CONTEÚDO • СОДЕРЖАНИЕ • CONTENUTO
 ZAWARTOŚĆ • OBSAH • OBSAH • INHOUD • INNEHÅLL • INDHOLD • ЗМІСТ • SISÄLLYS

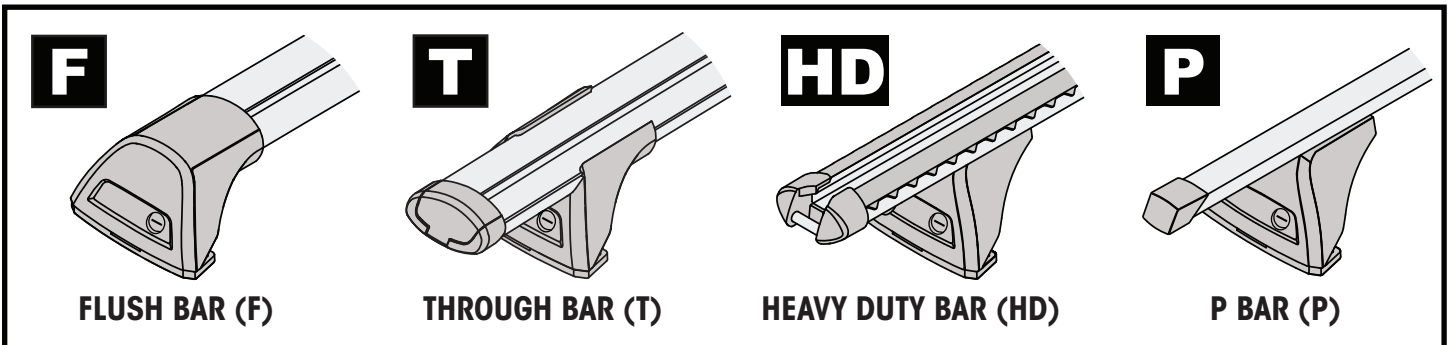
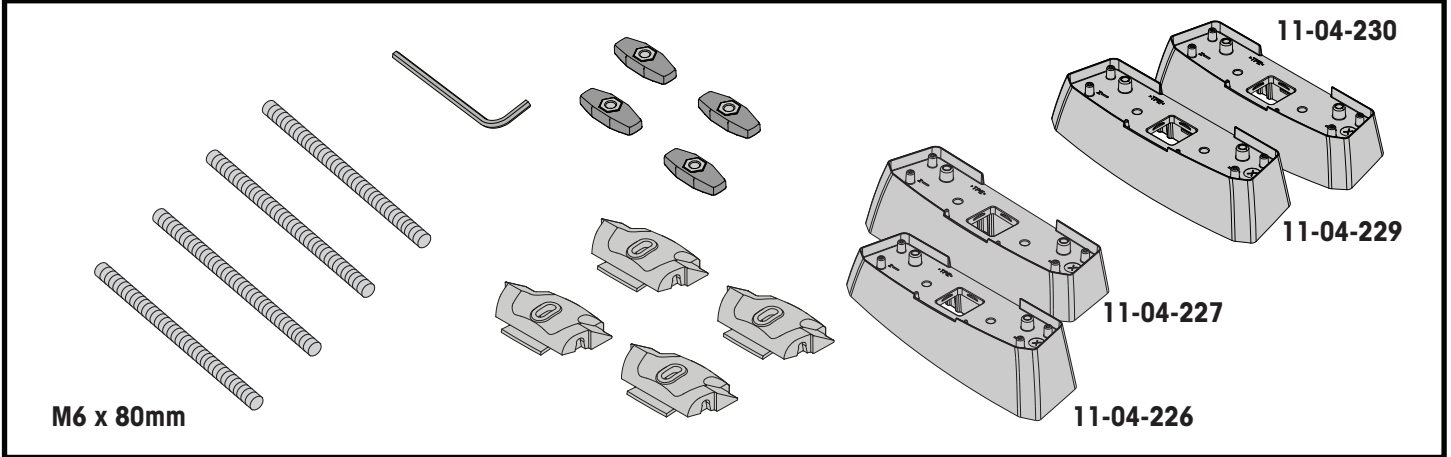

CONTENTS • INHALT • CONTENIDO • CONTENU • INNHOLD • CONTEÚDO • СОДЕРЖАНИЕ • CONTENUTO
 ZAWARTOŚĆ • OBSAH • OBSAH • INHOUD • INNEHÅLL • INDHOLD • ЗМІСТ • SISÄLLYS

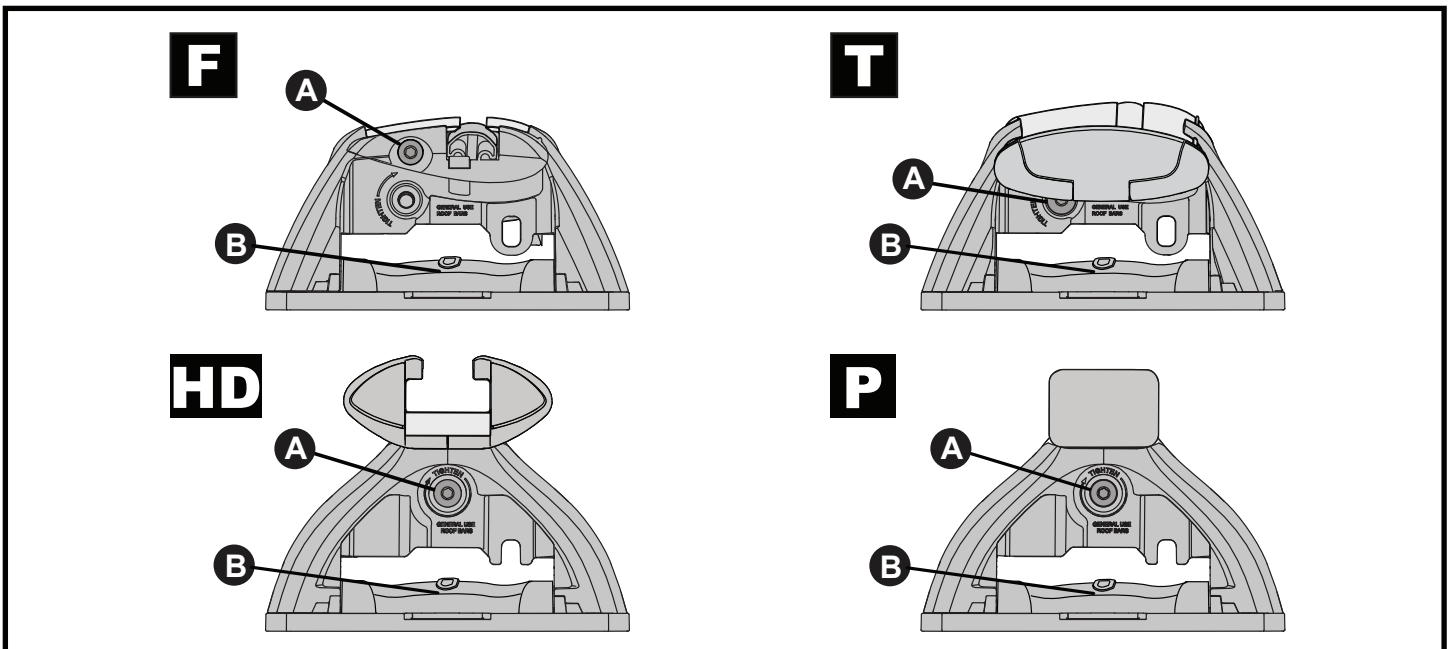
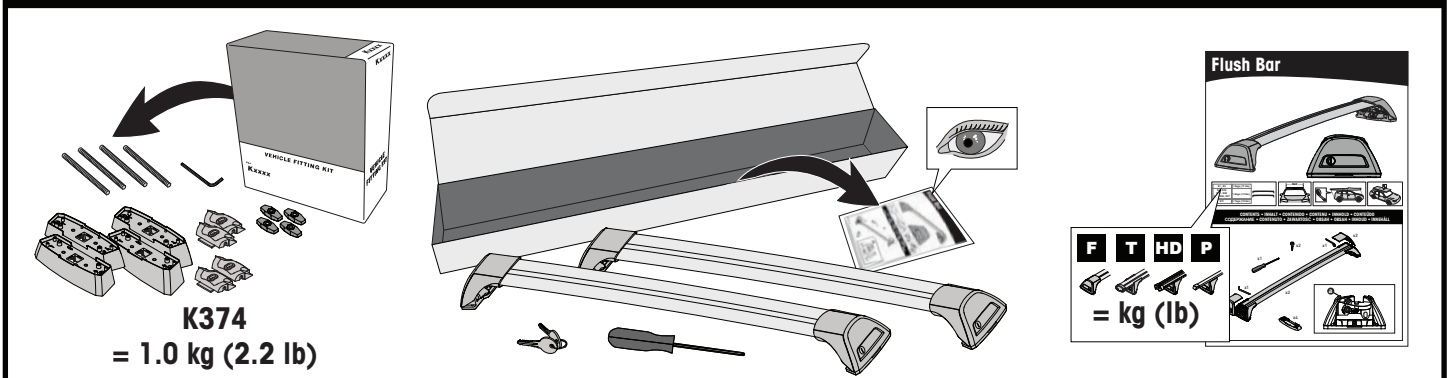

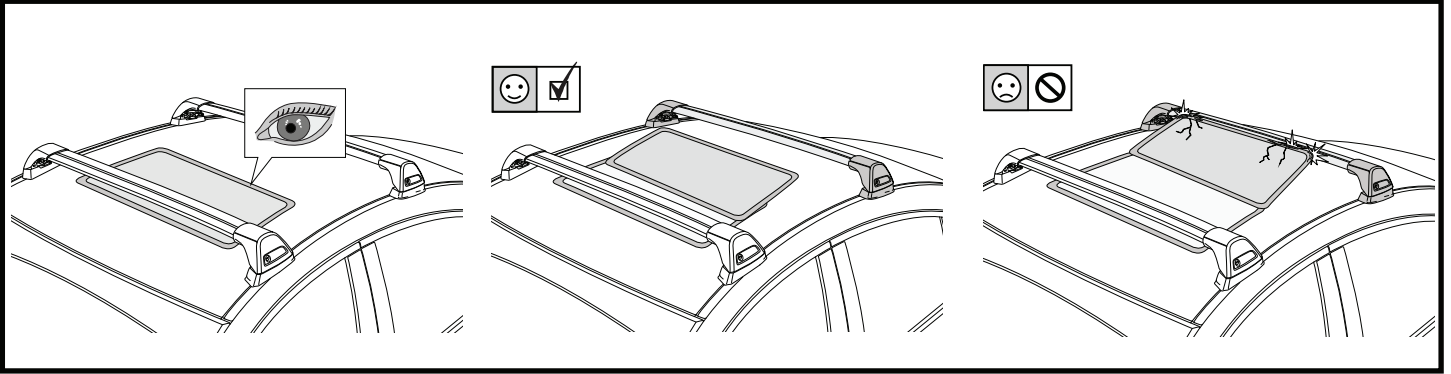

1

F **HD/P**

T **HD** **P**

x4

2

HD/P

F/T

x10

a

x4

3

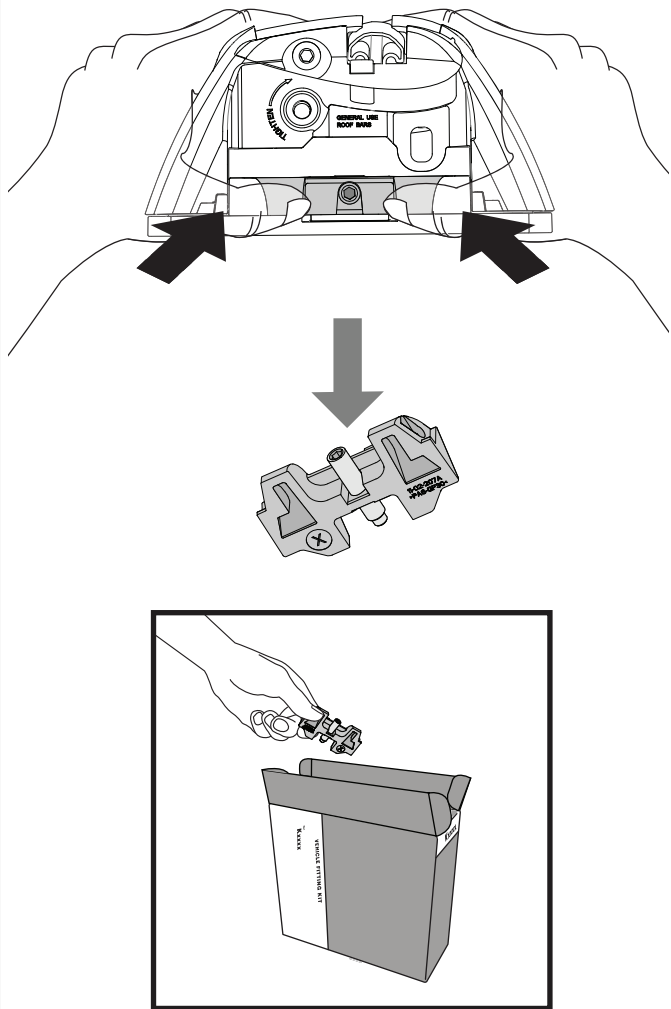

x4

4

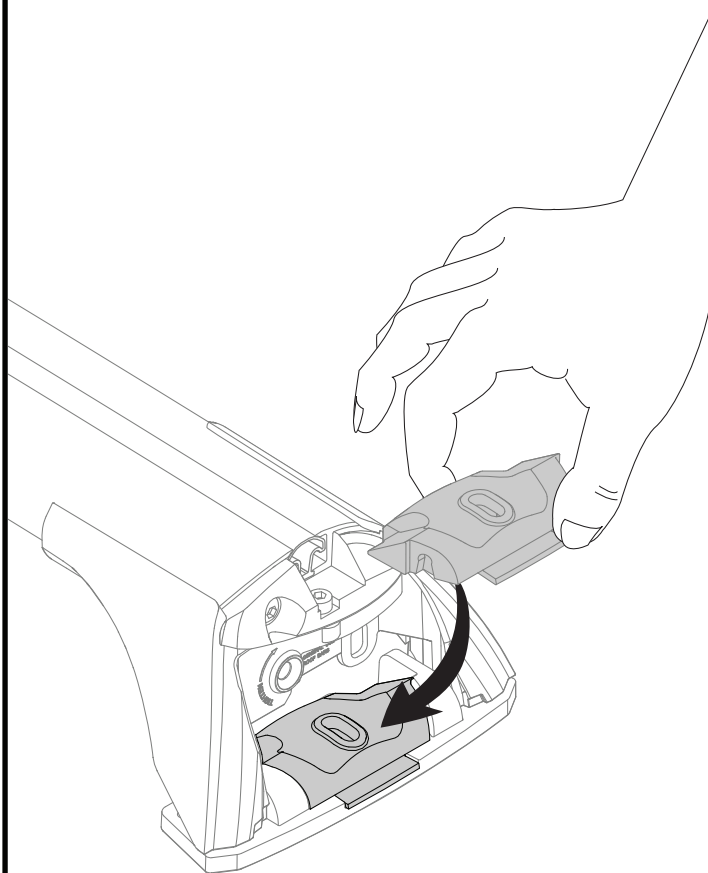

x4

5

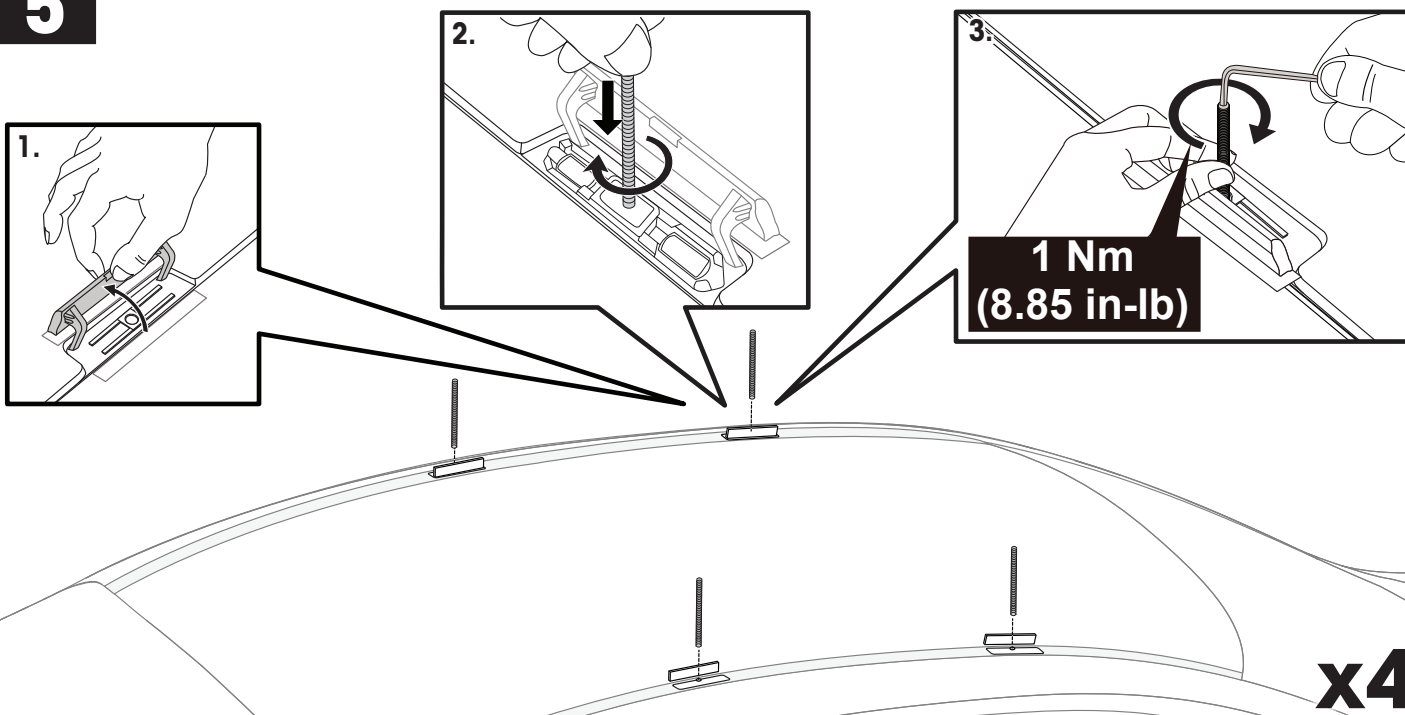

x4

6

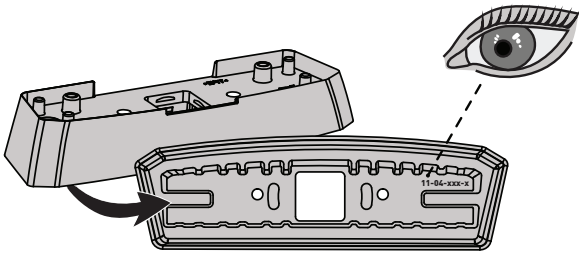

FR = 11-04-226

FL = 11-04-227

RR = 11-04-230

RL = 11-04-229

PLACEMENT • PLATZIERUNG • COLOCACIÓN • MONTAGE • PLASSERING • COLOCAÇÃO • РАЗМЕЩЕНИЕ • MONTAGGIO
 UMIESZCZENIE • UMÍSTĚNÍ • UMIESTNENIE • PLAATSING • PLACERING • PLACERING • РОЗМІЩЕННЯ • SIJOITTA

7

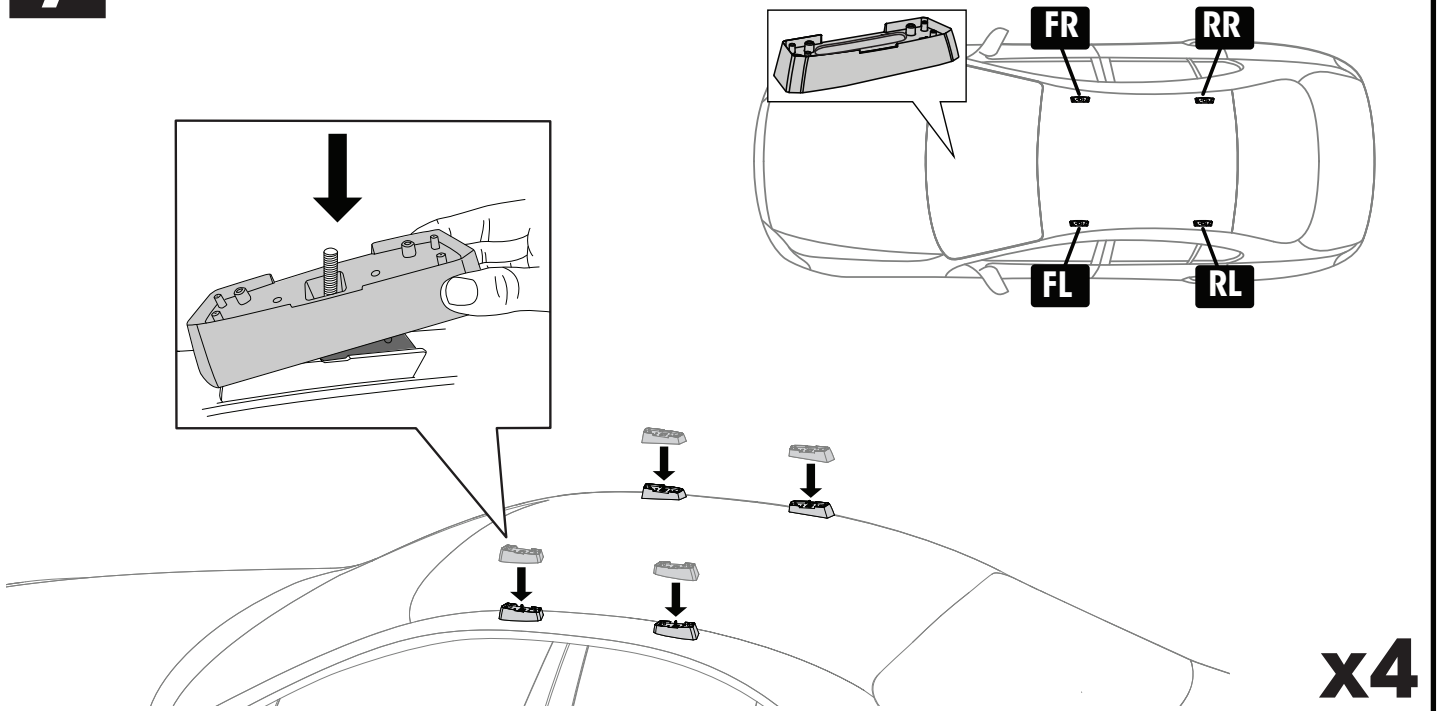

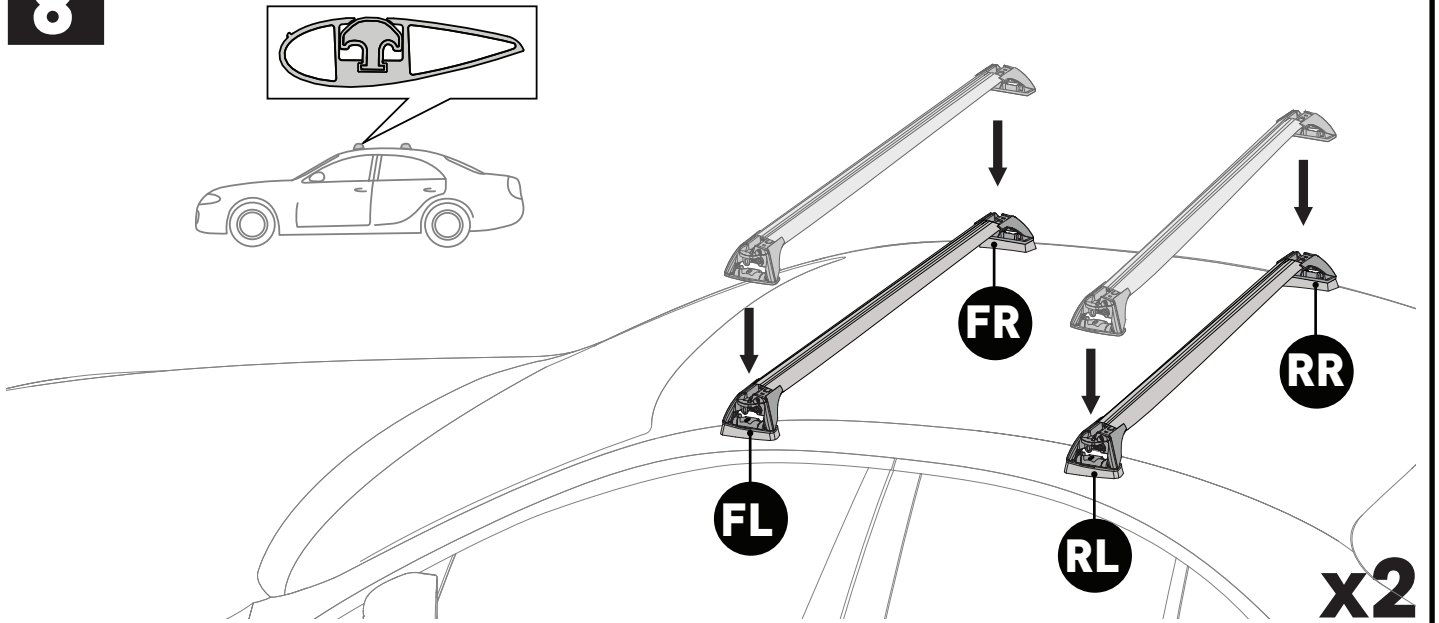

8

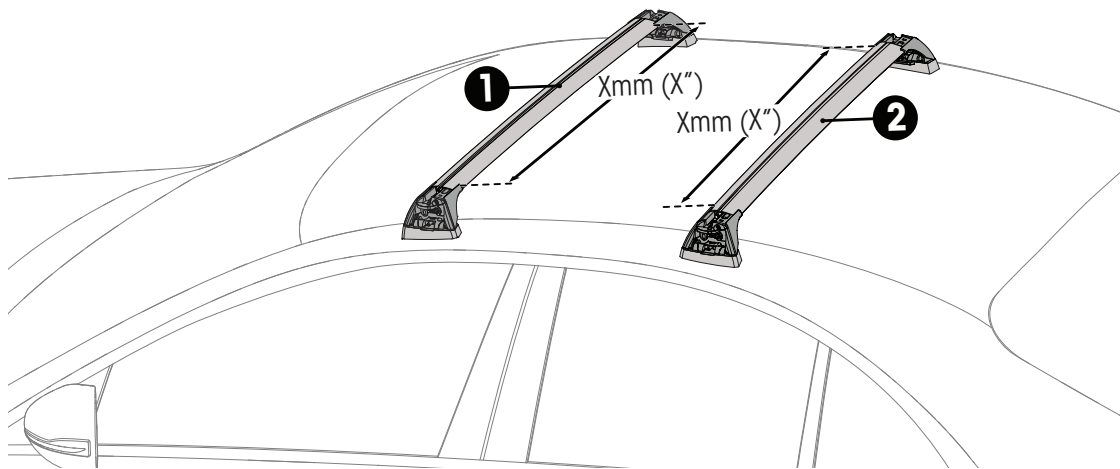
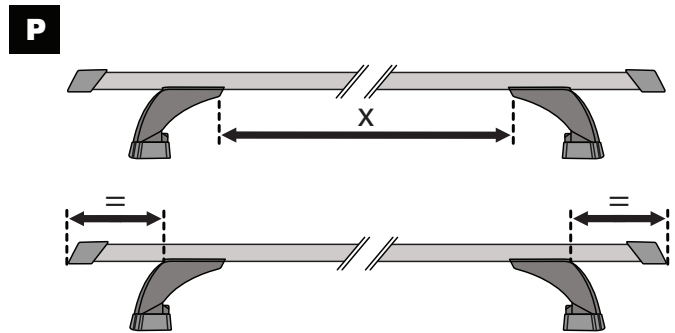
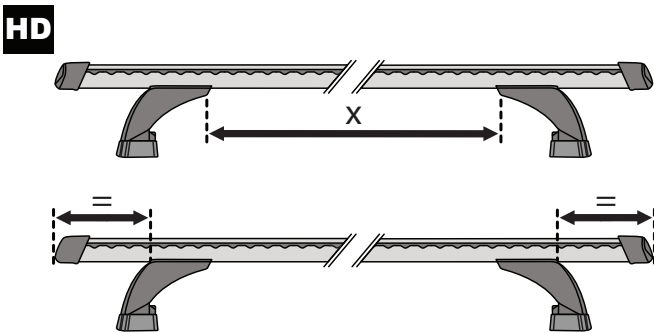
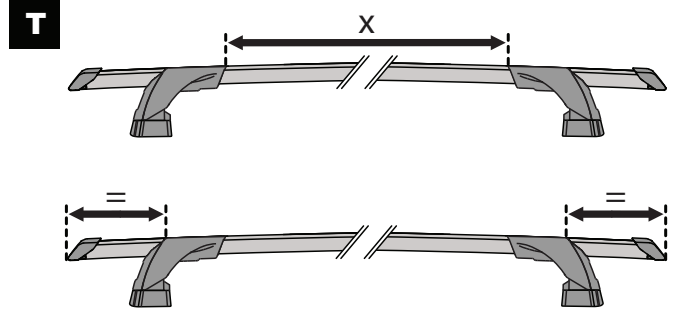
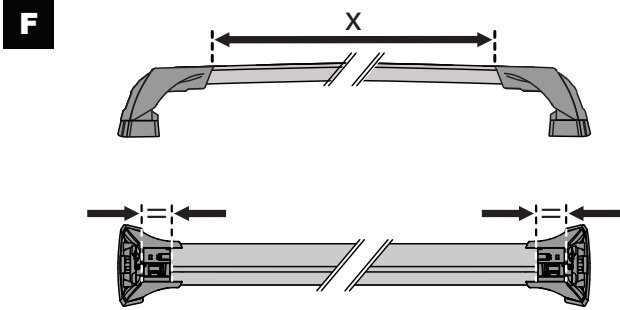
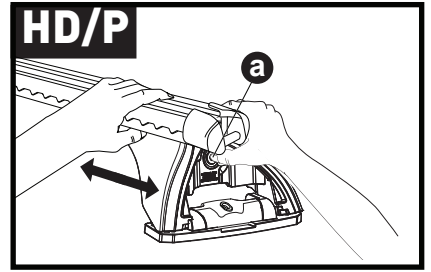
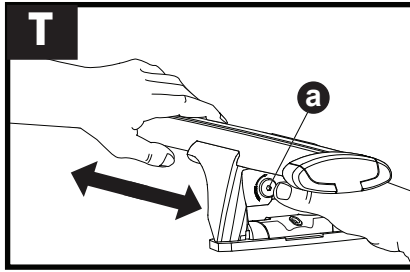
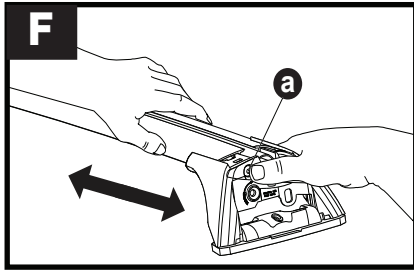

9



		1	2	A	B
BMW 3 Series E46 Compact, 3dr Hatch 00-04	EU	X = 810 mm (31 7/8")	X = 795 mm (31 1/4")	-A = 450 mm (17 3/4")	B = 260 mm (10 1/4")
BMW 3 Series E46 Compact, 3dr Hatch 01-04	AU, NZ, ZA	X = 810 mm (31 7/8")	X = 795 mm (31 1/4")	-A = 450 mm (17 3/4")	B = 260 mm (10 1/4")
BMW 3 Series E46, 4dr Sedan 99-04	EU, ZA	X = 800 mm (31 1/2")	X = 780 mm (30 3/4")	-A = 290 mm (11 3/8")	B = 430 mm (16 7/8")
BMW 3 Series E46, 4dr Sedan Jul 99-May 04	NZ	X = 800 mm (31 1/2")	X = 780 mm (30 3/4")	-A = 290 mm (11 3/8")	B = 430 mm (16 7/8")
BMW 3 Series E46, 4dr Sedan Oct 99-May 04	AU	X = 800 mm (31 1/2")	X = 780 mm (30 3/4")	-A = 290 mm (11 3/8")	B = 430 mm (16 7/8")

10

**2Nm
(18 lb-in)**

a

x4

11

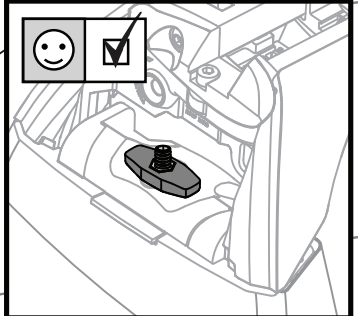
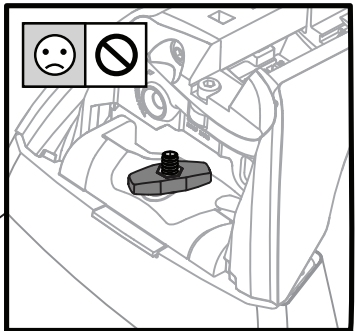
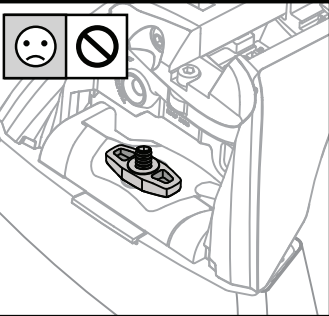

x4

12

**T
HD
P**

F

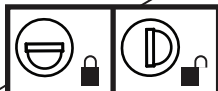

x4

13

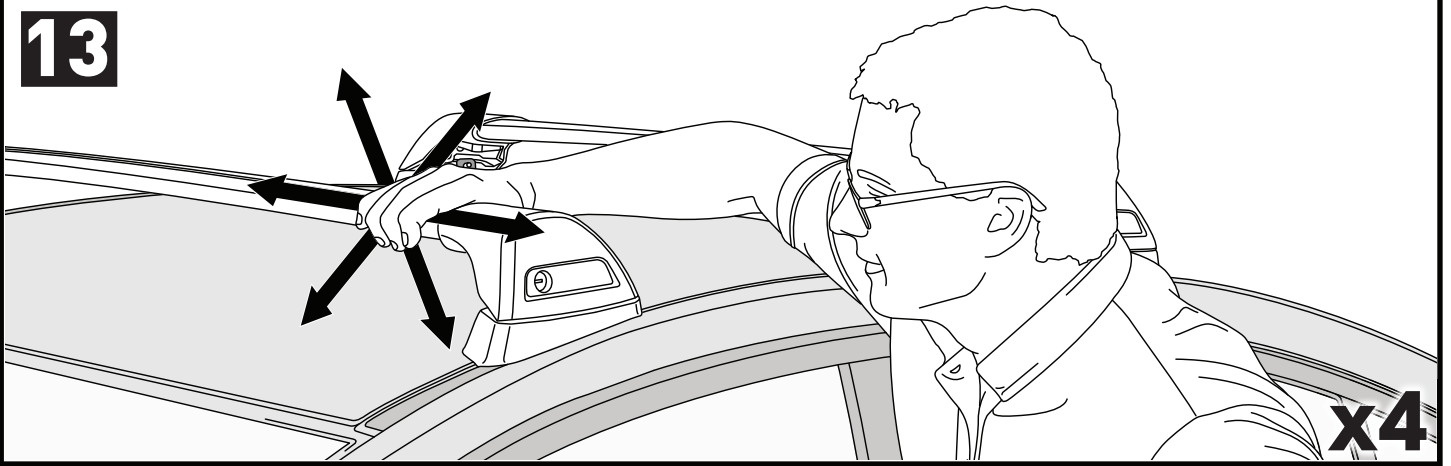

**ATTENTION • ACHTUNG • ATENCIÓN • ATTENTION • OPPMERKSOMHET • ATENÇÃO • ВНИМАНИЕ • ATTENZIONE
 UWAGA • UPOZORNĚNÍ • UPOZORNENIE • LET OP • UPPMÄRKSAMHET • OPMÆRKSOMHED • УВАГА • HUOMIO**

- EN** Please read safety and warranty booklet included with this product prior to use. For more information visit your local dealer.
- DE** Bitte lesen und beachten Sie die beiliegende Montageanleitung, Sicherheitshinweise und Garantiebedingungen bevor Sie das Produkt montieren/benutzen. Für weitere Informationen kontaktieren Sie bitte Ihren Händler.
- ES** Por favor, lea folleto de seguridad y garantía que se incluye con este producto antes de su uso. Para obtener más información, visite a su distribuidor local.
- FR** Veuillez lire attentivement le manuel de sécurité et de garantie avant utilisation. Pour plus d'informations, visitez votre concessionnaire local.
- NO** Vennligst les hefte om sikkerhet og garanti som er vedlagt dette produkt før det tas i bruk. For mer informasjon ta kontakt med din forhandler.
- PT** Por favor leia o manual de segurança e garantia incluído, antes de utilizar o produto. Para mais informações visite o seu revendedor local.
- RU** Пожалуйста, ознакомьтесь с инструкцией перед тем, как использовать товар. Для получения более подробной информации обратитесь к местному дилеру.
- IT** Si prega di leggere il libretto di sicurezza e garanzia incluso nel prodotto prima dell'uso. Per maggiori informazioni visita il rivenditore locale.
- PL** Proszę zapoznać się z warunkami gwarancji i bezpieczeństwa przed użyciem produktu. W celu uzyskania dodatkowych informacji proszę kontaktować się z najbliższym autoryzowanym punktem sprzedaży.
- CS** Před použitím si prosím přečtěte přiložené informace o bezpečnosti a záručních podmínkách. Pro více informací navštivte nejbližšího dealera.
- SK** Pred použitím si prosím prečítajte priložené informácie o bezpečnosti a záručných podmienkach. Pre viac informácií navštívte najbližšieho diera.
- NL** A.U.B. bijgesloten garantie- en veiligheidsinstructies grondig lezen voor gebruik van dit product. Voor meer informatie graag contact opnemen met uw dealer.
- SV** Var snäll och läs igenom säkerhets- och garantihäftet som medföljer produkten före användning. För mer information besök din lokala återförsäljare.
- DK** Læs venligst sikkerheds- og garantibogholderen, der følger med dette produkt, inden brug. For mere information besøg din lokale forhandler.
- UA** Будь ласка, ознайомтеся з бронею безпеки та гарантії, включені до цього продукту перед використанням. Для отримання додаткової інформації відвідайте місцевого дилера.
- FI** Lue tämän tuotteen mukana toimitetut turvallisuus- ja takuu huoltopalvelut ennen käyttöä. Lisätietoja saat paikalliselta jälleenmyyjältä.

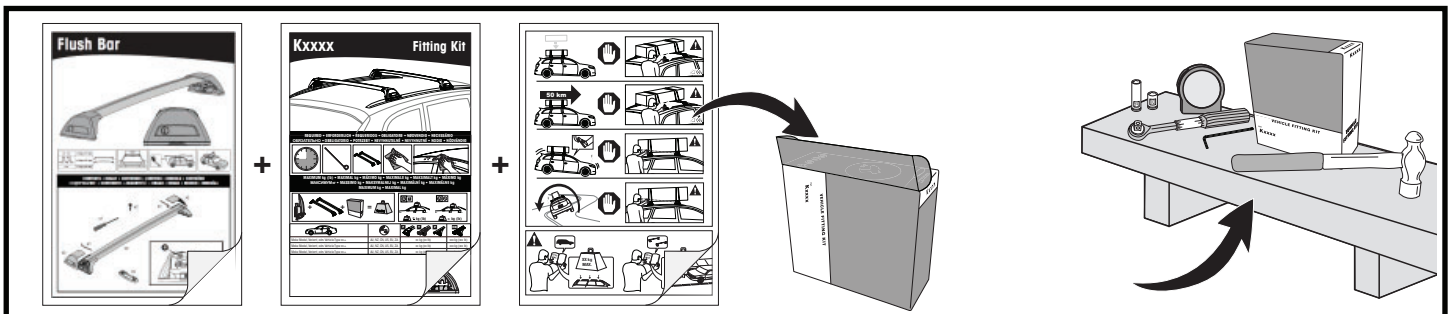
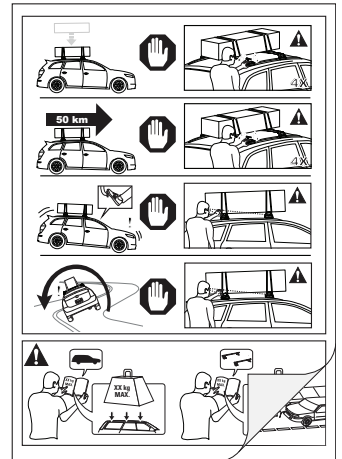

Yakima Australia Pty Ltd
 17 Hinkler Court, Brendale
 QLD 4500, Australia
 1800 143 548
www.prorack.com.au
www.whispbar.com.au

Yakima Europe Coöperatief U.A.
 Twentehaven 7, 3433
 PT Nieuwegein, The Netherlands
 +31 2080 81425
www.prorackeurope.eu
www.yakima.eu

Yakima Products, Inc.
 4101 Kruse Way
 Lake Oswego, OR. 97035 USA
 888 925 4621
www.yakima.com

WORKS WITH:
YAKIMA
 WHISPBAR
Prorack