

K590

Fitting Kit

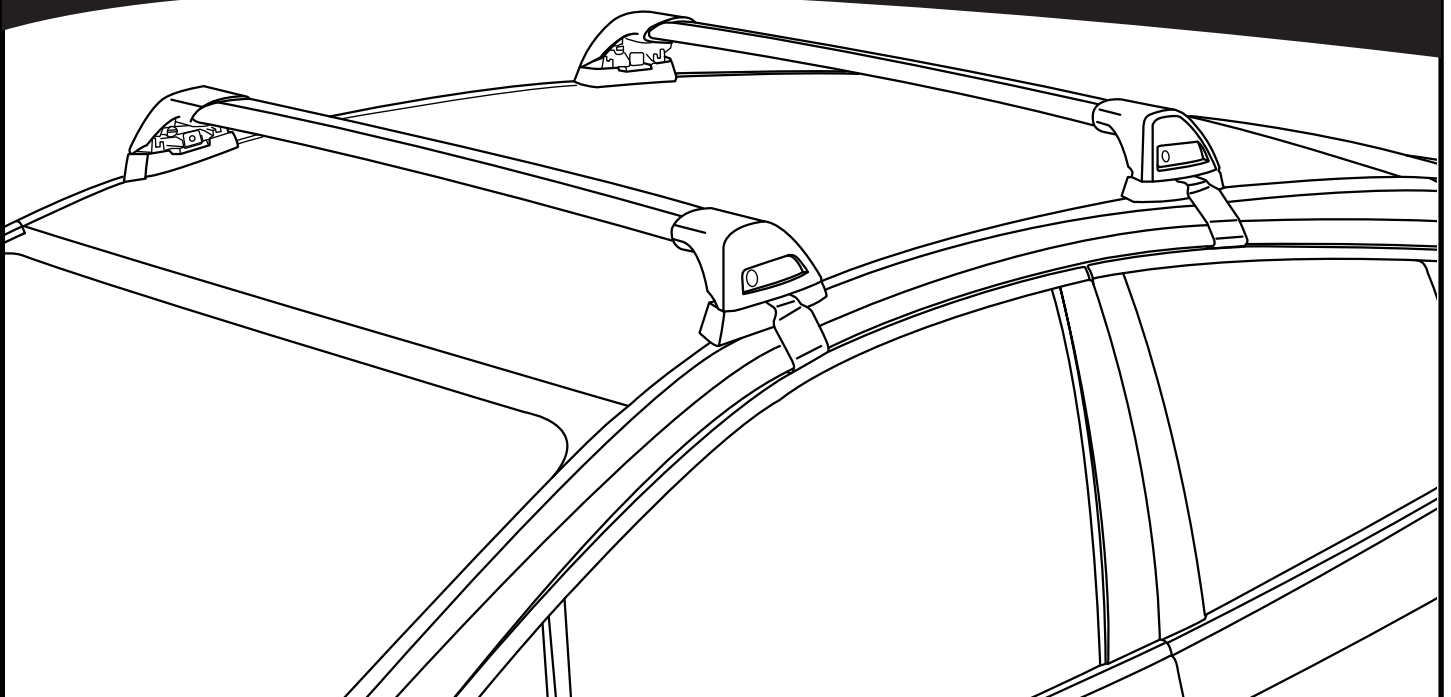

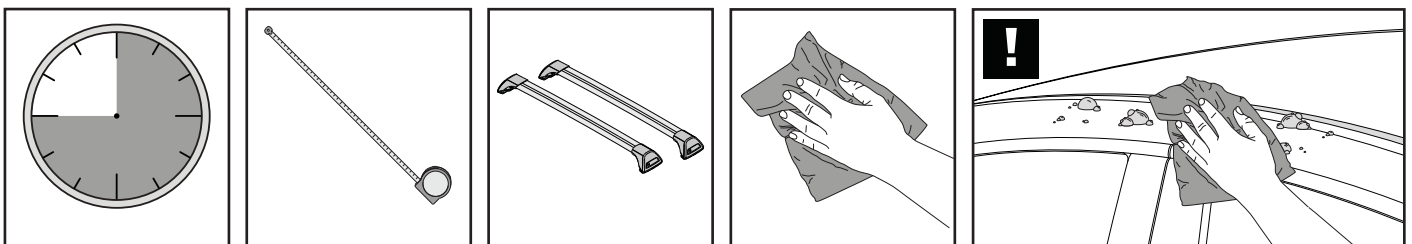



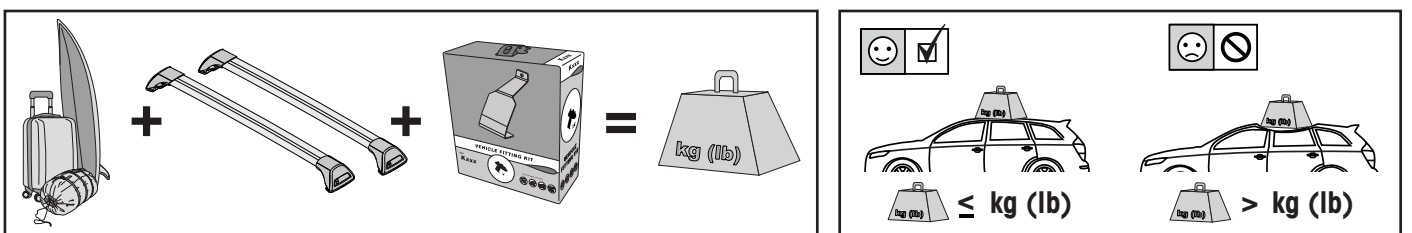

**REQUIRED • ERFORDERLICH • REQUERIDOS • OBLIGATOIRE • NØDVENDIG • NECESSÁRIO
ОБЯЗАТЕЛЬНО • OBLIGATORIO • POTRZEBY • NEVYHNUTELNÉ • NEVYHNUTNÉ • NODIG • NØDVÄNDIG**



**MAXIMUM kg (lb) • MAXIMUM kg • MÁXIMO kg • MAXIMUM kg • MAKSIMALT kg • MÁXIMO kg
МАКСИМУМ кг • MASSIMO kg • MAKSIMALNEJ kg • MAXIMÁLNÍ kg • MAXIMÁLNE kg
MAXIMUM kg • MAXIMAL kg**



		  	
Alfa Romeo Giulietta, 5dr Hatch 10-13	AU, CN, EU, NZ, ZA	50 kg (110 lb)	50 kg (110 lb)
Alfa Romeo Giulietta, 5dr Hatch 14+	AU, CN, EU, NZ, ZA	50 kg (110 lb)	50 kg (110 lb)

**CONTENTS • INHALT • CONTENIDO • CONTENU • INNHOLD • CONTEÚDO • СОДЕРЖАНИЕ • CONTENUTO
ZAWARTOŚĆ • OBSAH • OBSAH • INHOUD • INNEHÅLL**

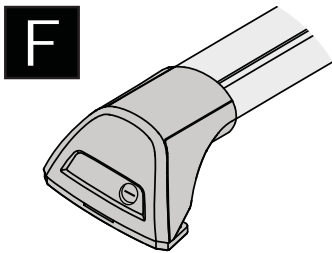
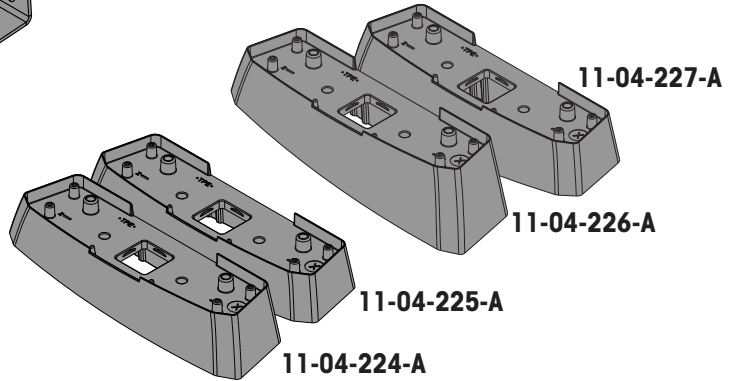
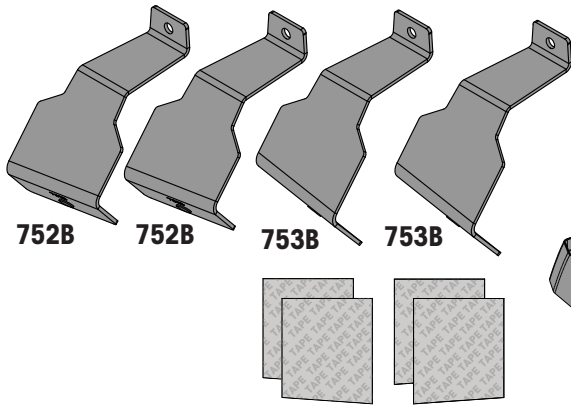

F
FLUSH BAR (F)

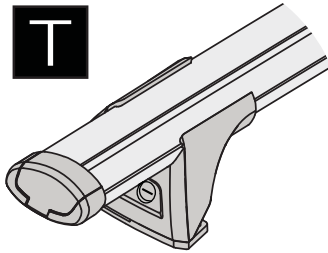

T
THROUGH BAR (T)

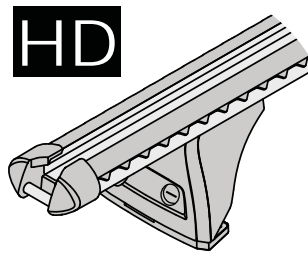

HD
HEAVY DUTY BAR (HD)

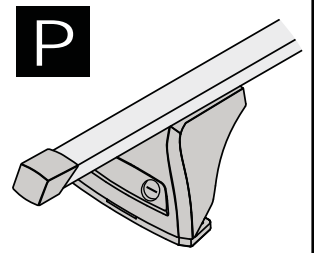

P
P BAR (P)

**ATTENTION • ACHTUNG • ATENCIÓN • ATTENTION • OPPMERKSOMHET • ATENÇÃO • ВНИМАНИЕ
ATTENZIONE • UWAGA • UPOZORNĚNÍ • UPOZORNENIE • LET OP • UPPMÄRSAMHET**

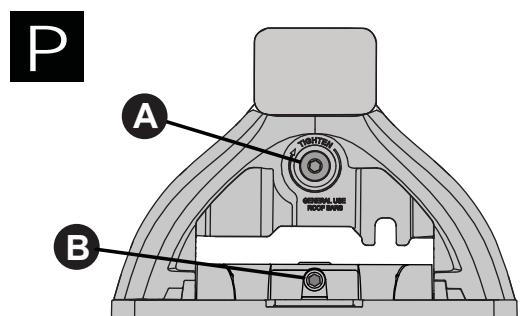
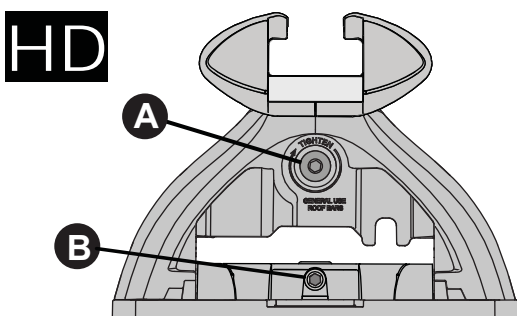
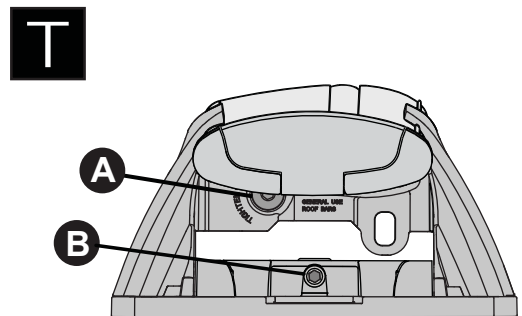
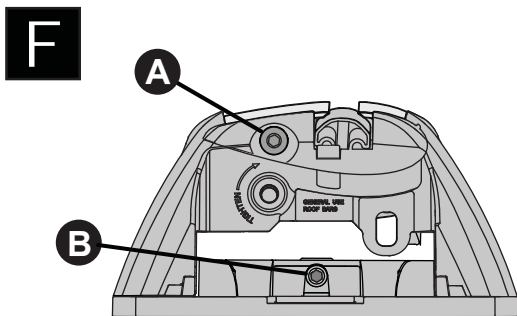
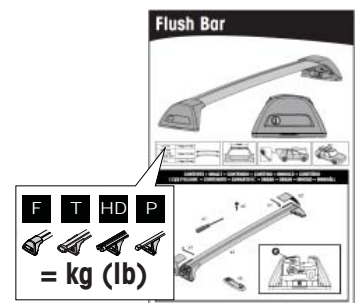
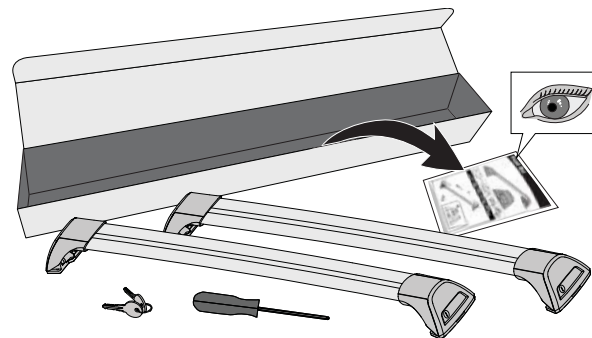

ATTENTION • ACHTUNG • ATENCIÓN • ATTENTION • OPPMERKSOMHET • ATENÇÃO • ВНИМАНИЕ
 ATTENZIONE • UWAGA • UPOZORNĚNÍ • UPOZORNENIE • LET OP • UPPMÄRKSAMHET

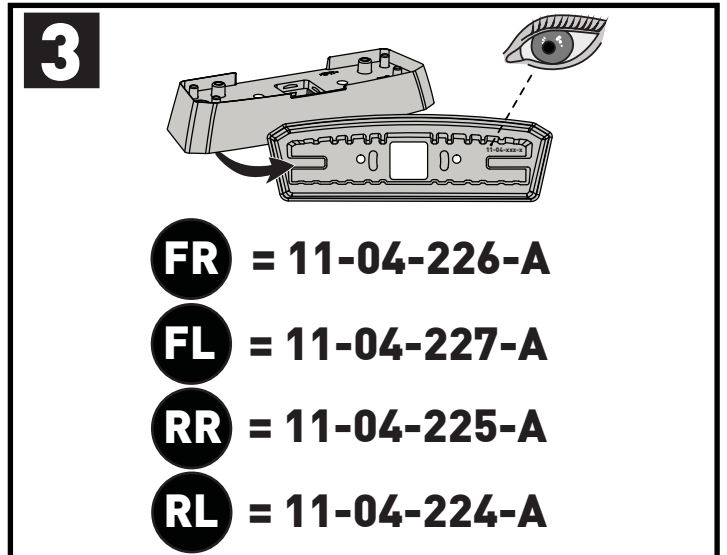
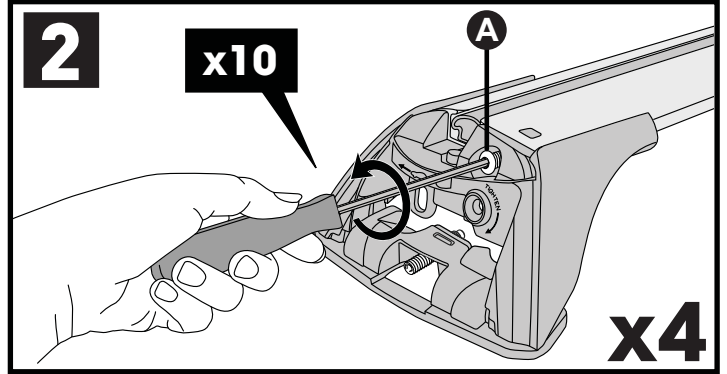
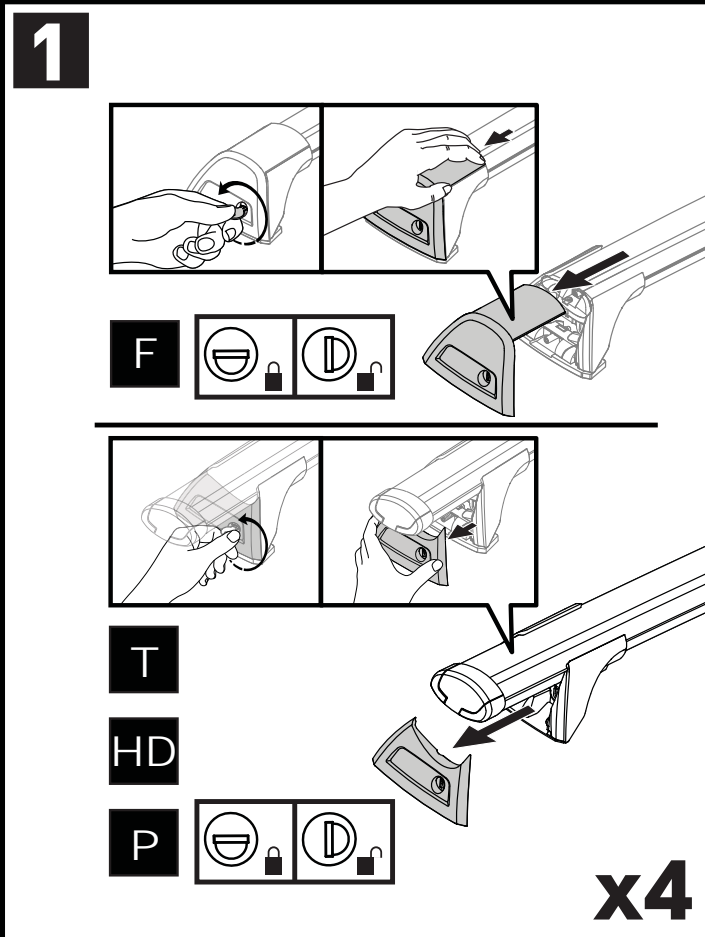
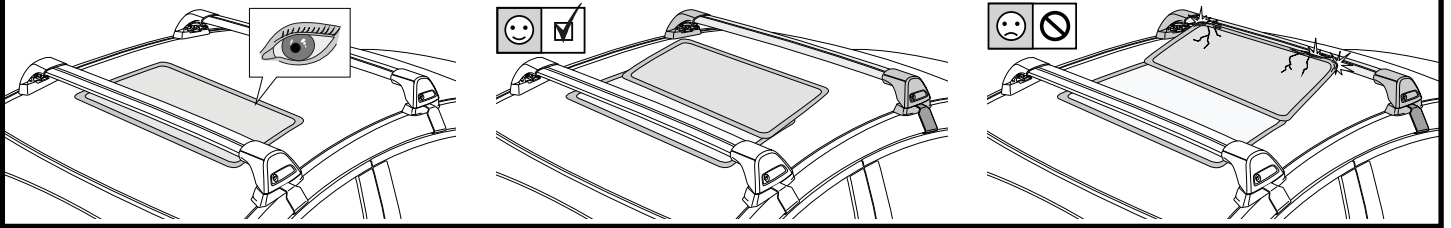

PLACEMENT • PLATZIERUNG • COLOCACIÓN • MONTAGE • PLASSERING • COLOCAÇÃO • РАЗМЕЩЕНИЕ
 MONTAGGIO • UMIESZCZENIE • UMÍSTĚNÍ • UMIESTNENIE • PLAATSING • PLACERING

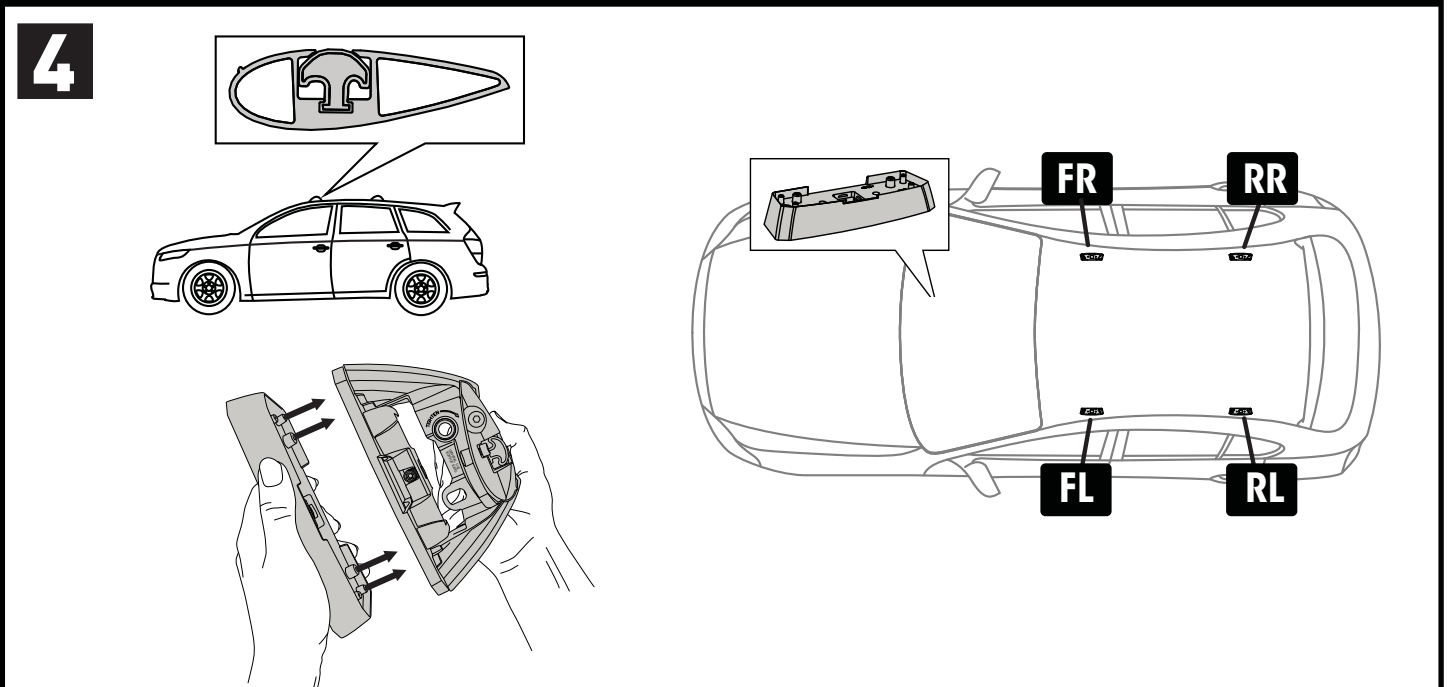

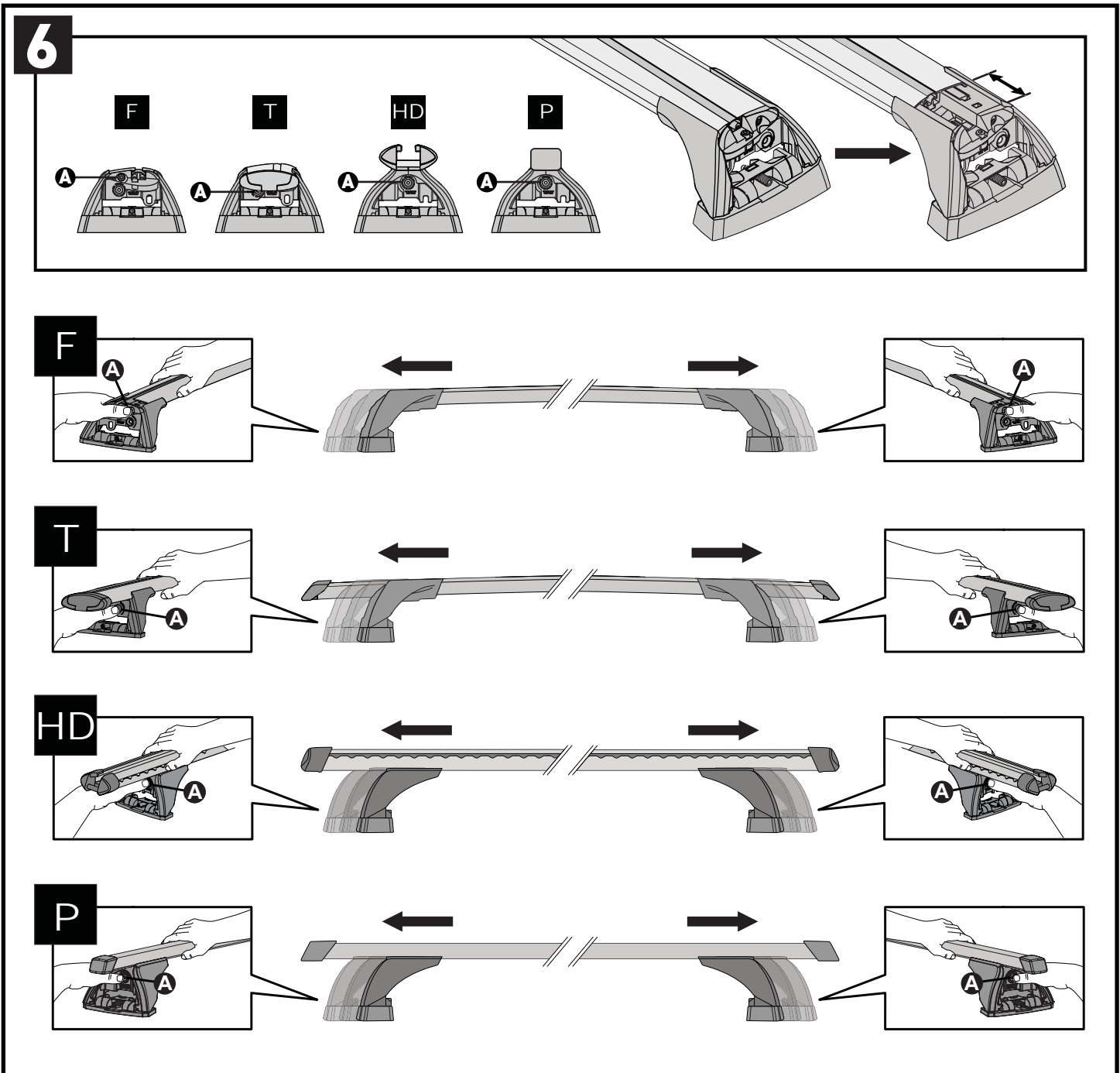
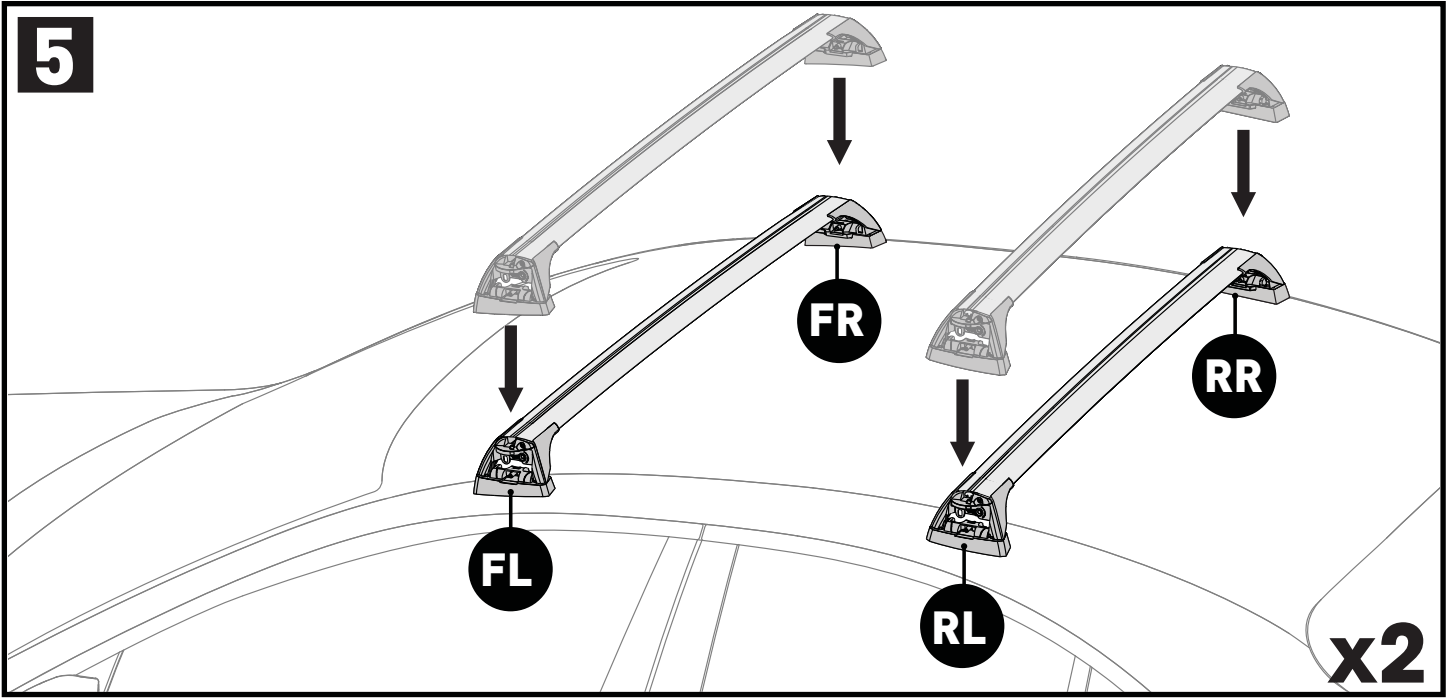

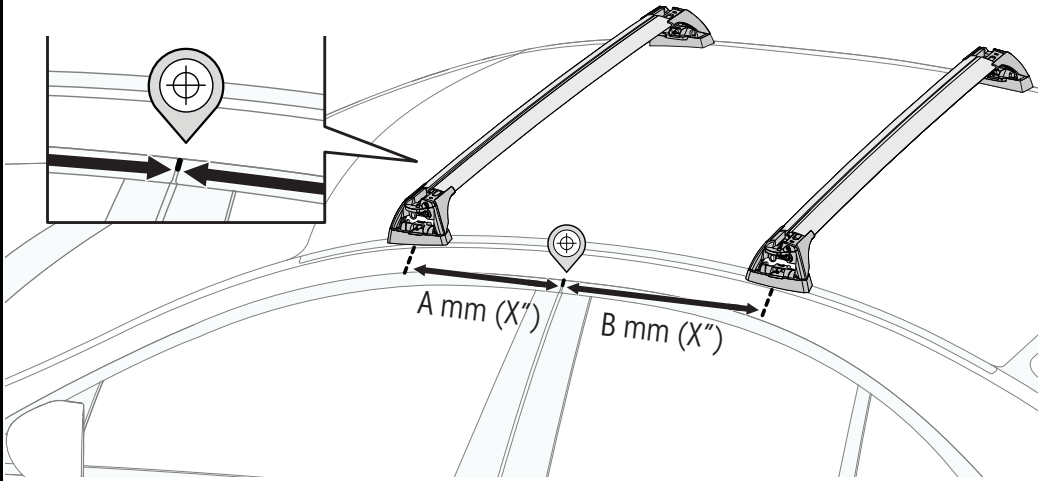
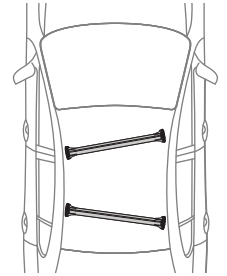
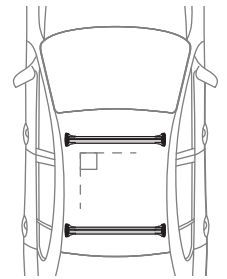

7

mm / inches



		A	B
Alfa Romeo Giulietta, 5dr Hatch 10-13	AU, CN, EU, NZ, ZA	360 mm (14 ³ / ₁₆ ")	400 mm (15 ³ / ₄ ")
Alfa Romeo Giulietta, 5dr Hatch 14+	AU, CN, EU, NZ, ZA	365 mm (14 ³ / ₈ ")	400 mm (15 ³ / ₄ ")

**PLACEMENT • PLATZIERUNG • COLOCACIÓN • MONTAGE • PLASSERING • COLOCAÇÃO • РАЗМЕЩЕНИЕ
MONTAGGIO • UMIESZCZENIE • UMÍSTĚNÍ • UMIESTNENIE • PLAATSING • PLACERING**

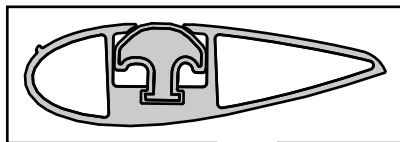
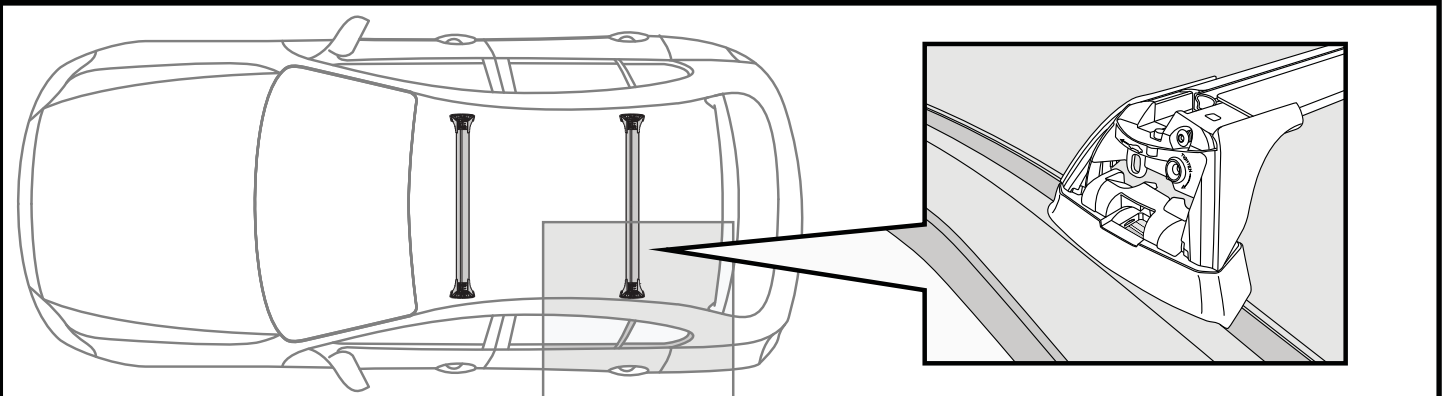

8

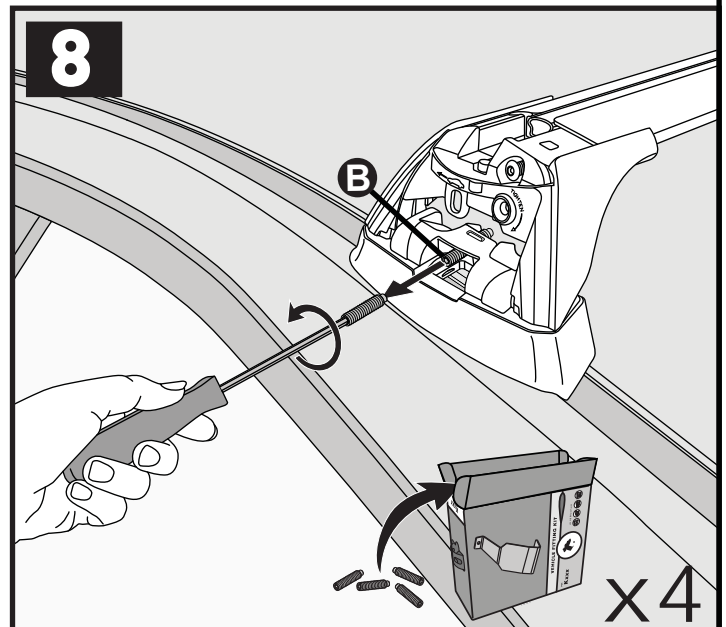

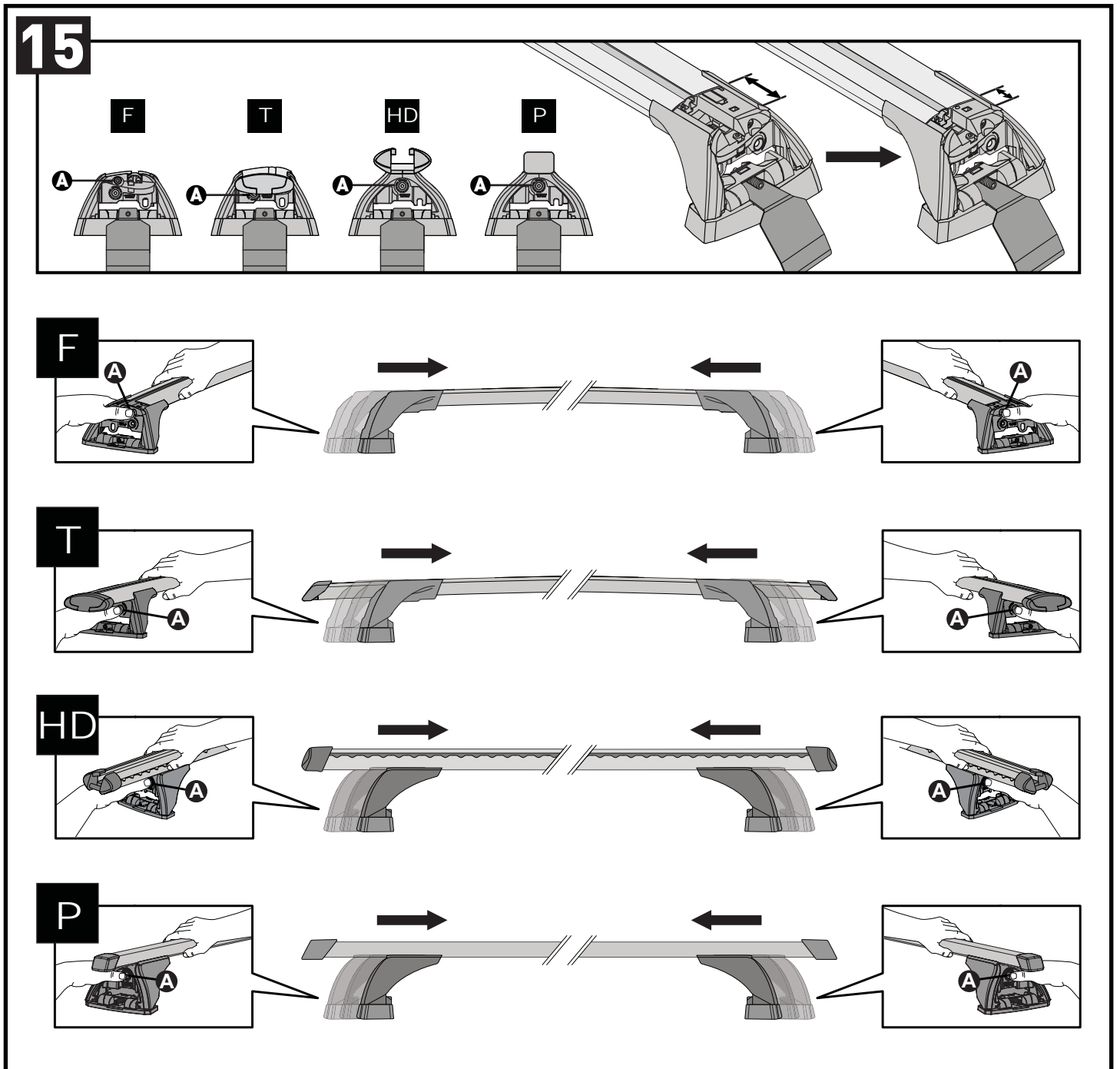
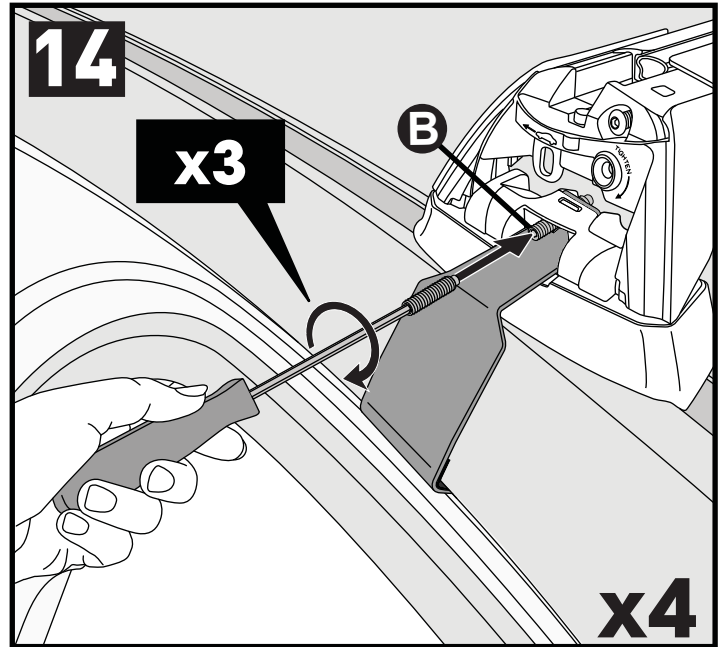
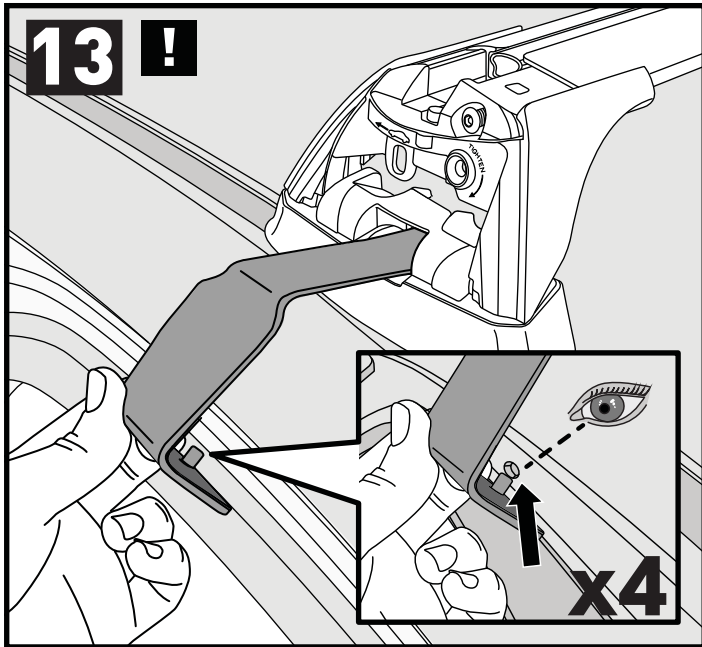

CLOSE • GESCHLOSSEN • CERRAR • FERMER • LUKKE • FECHAR • ЗАКРЫТЬ • SERRARE • BLISKO
 ZAVŘÍT • ZAVRIĚT • GESLOTEN • STÄNGA

16

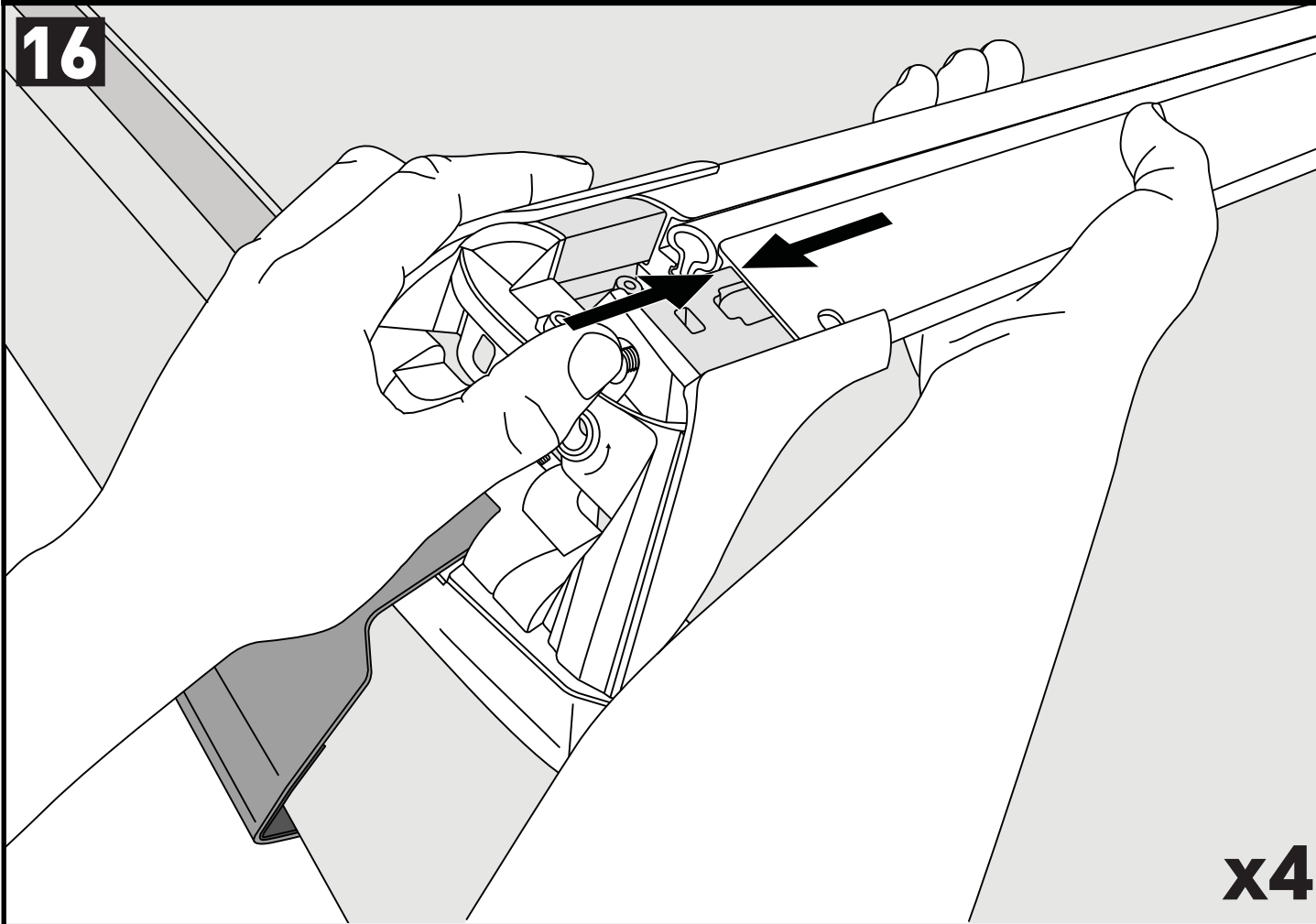

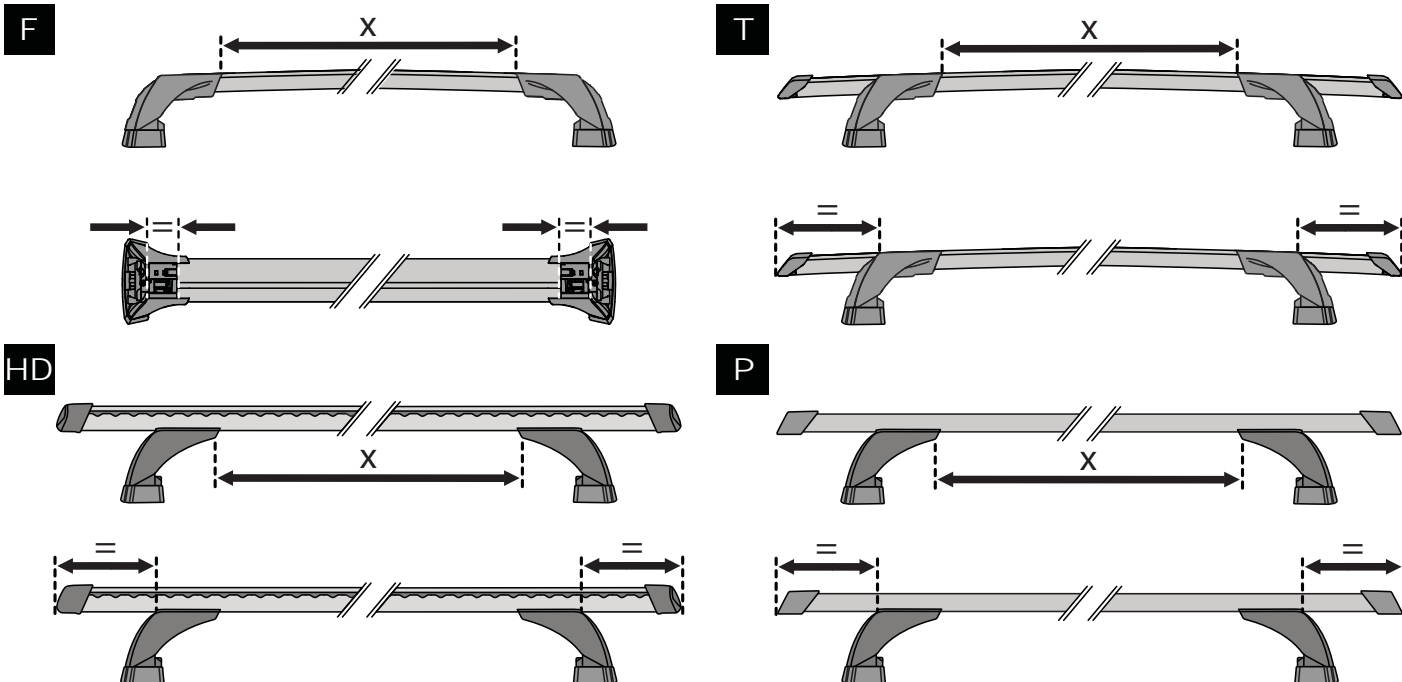

x4

ATTENTION • ACHTUNG • ATENCIÓN • ATTENTION • OPPMERKSOMHET • ATENÇÃO • ВНИМАНИЕ
 ATTENZIONE • UWAGA • UPOZORNĚNÍ • UPOZORNENIE • LET OP • UPPMÄRKSAMHET

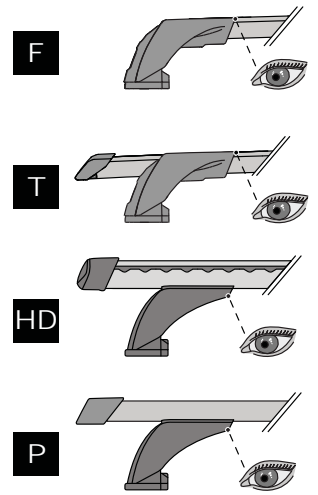
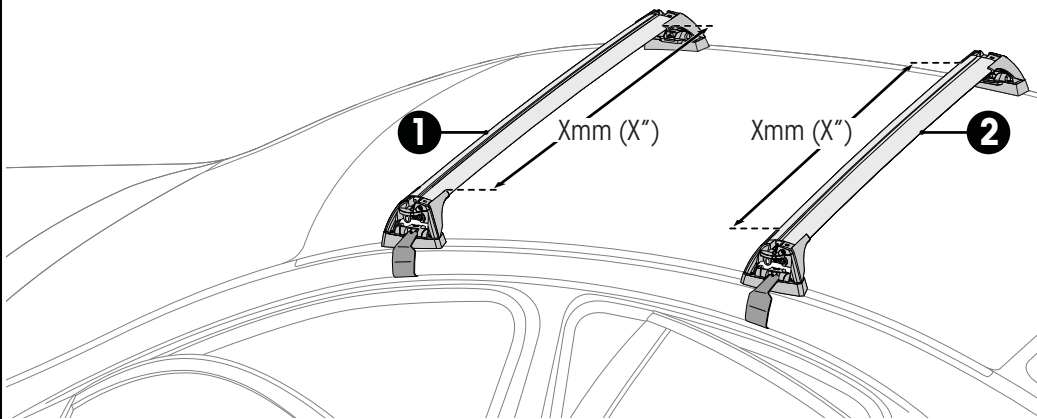

19



		1	2
Alfa Romeo Giulietta, 5dr Hatch 10-13	AU, CN, EU, NZ, ZA	X = 805 mm (31 11/16")	X = 775 mm (30 1/2")
Alfa Romeo Giulietta, 5dr Hatch 14+	AU, CN, EU, NZ, ZA	X = 805 mm (31 11/16")	X = 775 mm (30 1/2")

20

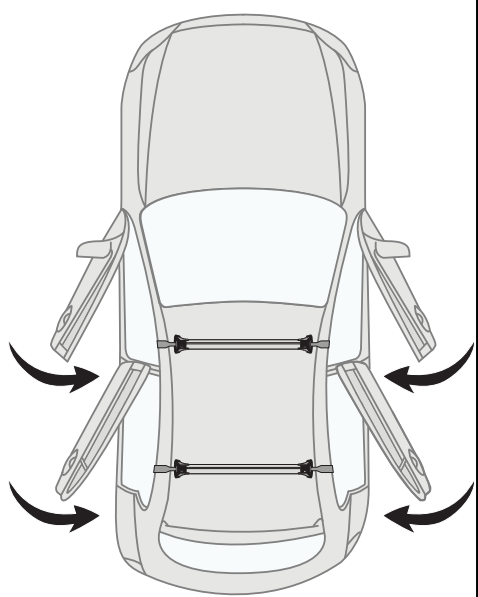

21



7 mm / inches

Make/Model/Variant	Vehicle Type	A	B
Alfa Romeo Giulietta	5dr Hatch	805 mm (31 11/16")	775 mm (30 1/2")
Alfa Romeo Giulietta	5dr Hatch	805 mm (31 11/16")	775 mm (30 1/2")
Alfa Romeo Giulietta	5dr Hatch	805 mm (31 11/16")	775 mm (30 1/2")

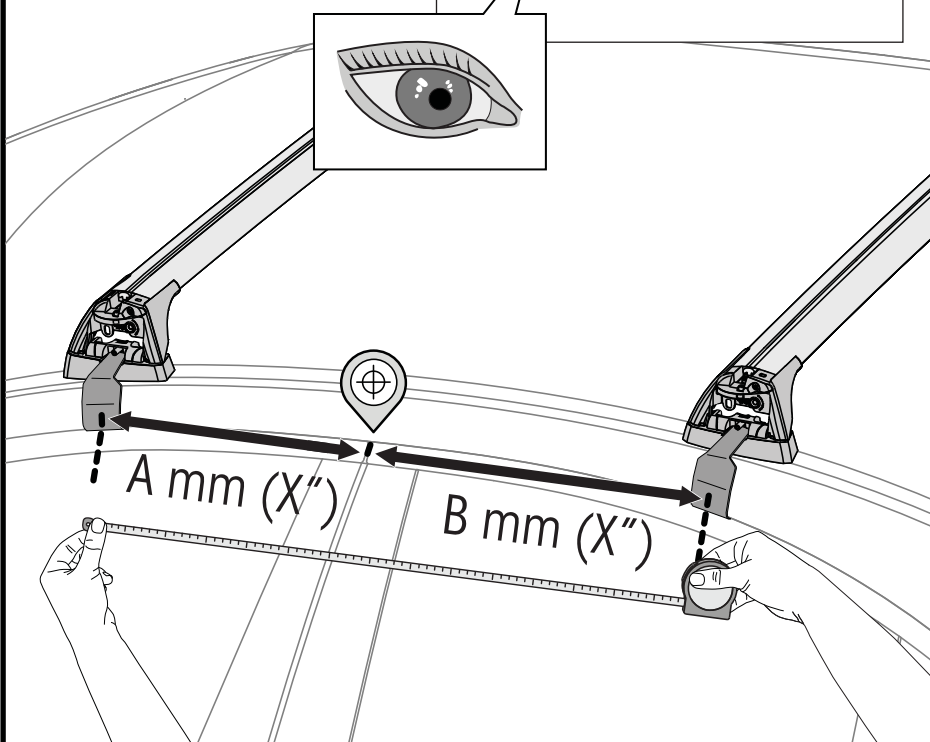

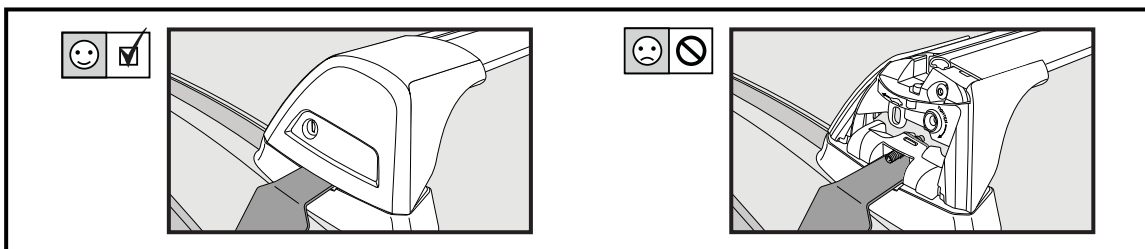
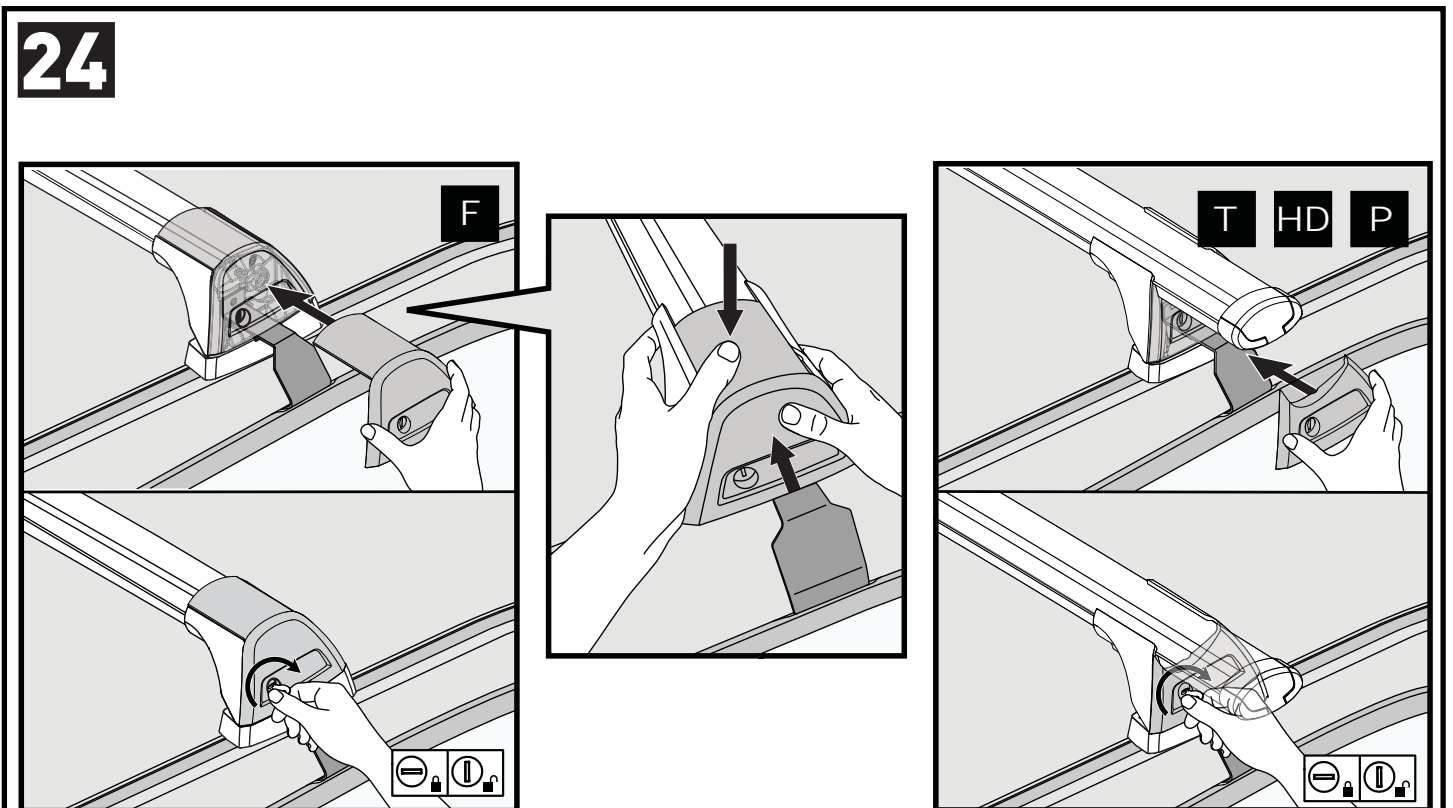
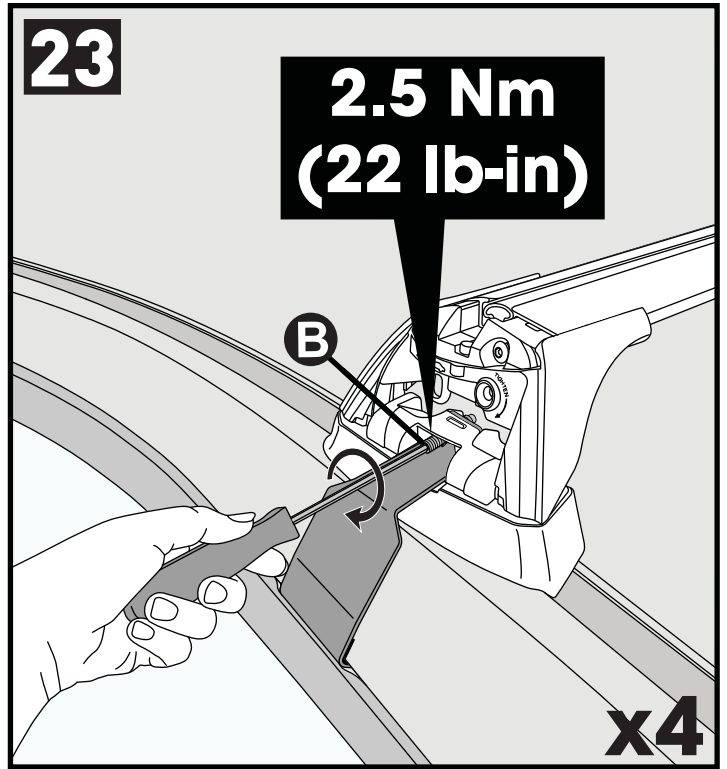
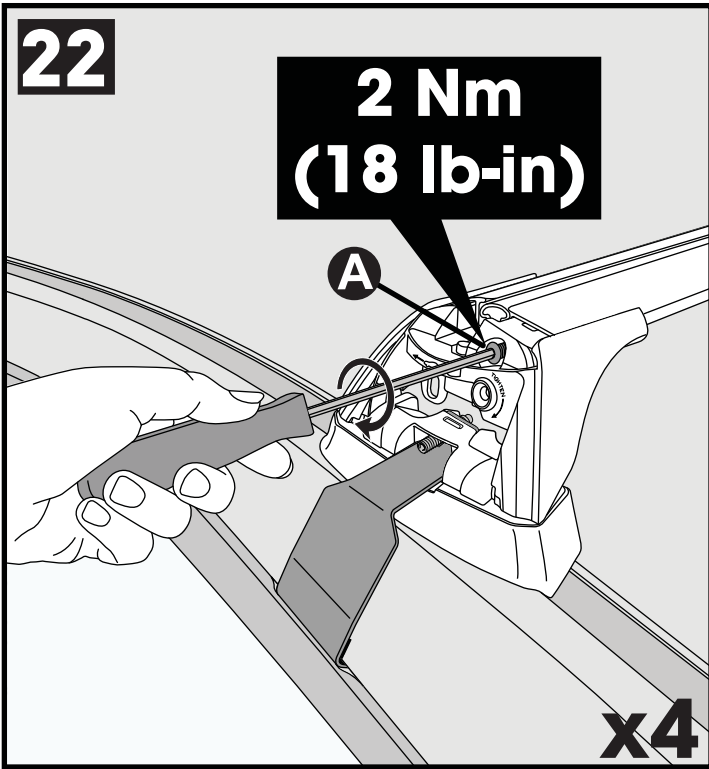

x4

25

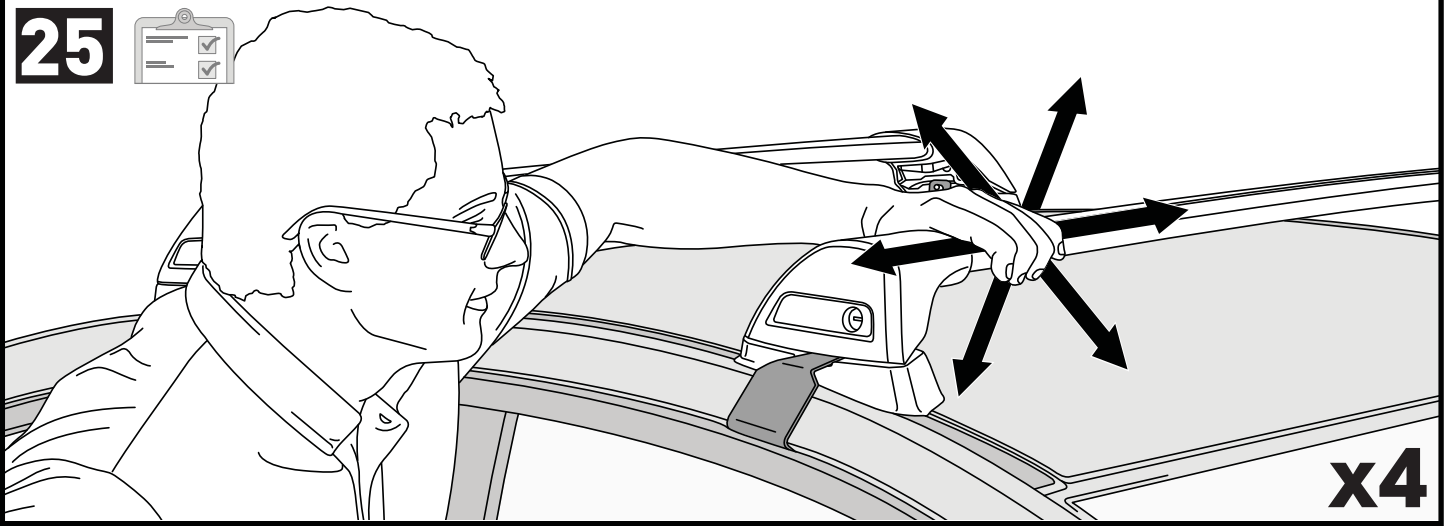

x4

**ATTENTION • ACHTUNG • ATENCIÓN • ATTENTION • OPPMERKSOMHET • ATENÇÃO • ВНИМАНИЕ
ATTENZIONE • UWAGA • UPOZORNĚNÍ • UPOZORNENIE • LET OP • UPPMÄRSAMHET**

- EN** Please read safety and warranty booklet included with this product prior to use. For more information visit your local dealer.
- DE** Bitte lesen und beachten Sie die beiliegende Montageanleitung, Sicherheitshinweise und Garantiebedingungen bevor Sie das Produkt montieren/benutzen. Für weitere Informationen kontaktieren Sie bitte Ihren Händler.
- ES** Por favor, lea folleto de seguridad y garantía que se incluye con este producto antes de su uso. Para obtener más información, visite a su distribuidor local.
- FR** Veuillez lire attentivement le manuel de sécurité et de garantie avant utilisation. Pour plus d'informations, visitez votre concessionnaire local.
- NO** Vennligst les hefte om sikkerhet og garanti som er vedlagt dette produkt før det tas i bruk. For mer informasjon ta kontakt med din forhandler.
- PT** Por favor leia o manual de segurança e garantia incluído, antes de utilizar o produto. Para mais informações visite o seu revendedor local.
- RU** Пожалуйста, ознакомьтесь с инструкцией перед тем, как использовать товар. Для получения более подробной информации обратитесь к местному дилеру.
- IT** Si prega di leggere il libretto di sicurezza e garanzia incluso nel prodotto prima dell'uso. Per maggiori informazioni visita il rivenditore locale.
- PL** Proszę zapoznać się z warunkami gwarancji i bezpieczeństwa przed użyciem produktu. W celu uzyskania dodatkowych informacji proszę kontaktować się z najbliższym autoryzowanym punktem sprzedaży.
- CS** Před použitím si prosím přečtete přiložené informace o bezpečnosti a záručních podmínkách. Pro více informací navštivte nejbližšího dealera.
- SK** Pred použitím si prosím prečítajte priložené informácie o bezpečnosti a záručných podmienkach. Pre viac informácií navštívte najbližšieho diera.
- NL** A.U.B. bijgesloten garantie- en veiligheidsinstructies grondig lezen voor gebruik van dit product. Voor meer informatie graag contact opnemen met uw dealer.
- SV** Var snabb och läs igenom säkerhets- och garantihäftet som medföljer produkten före användning. För mer information besök din lokala återförsäljare.

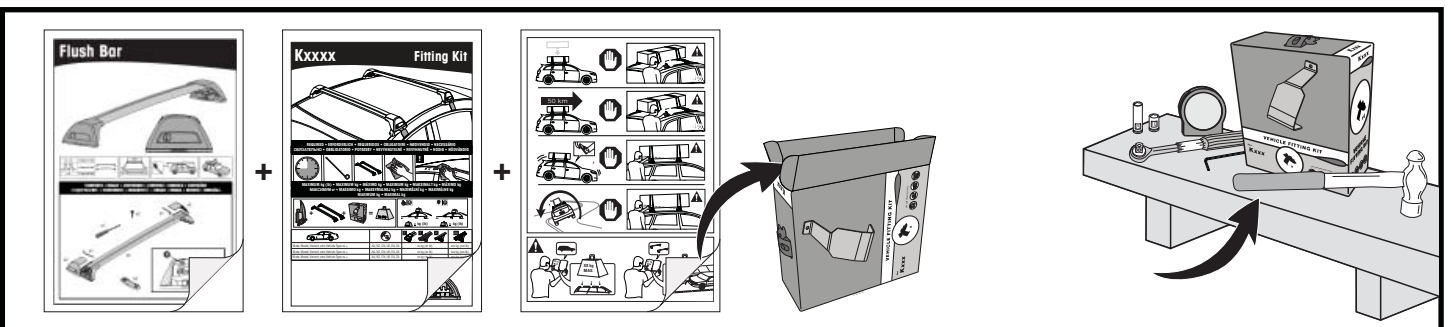
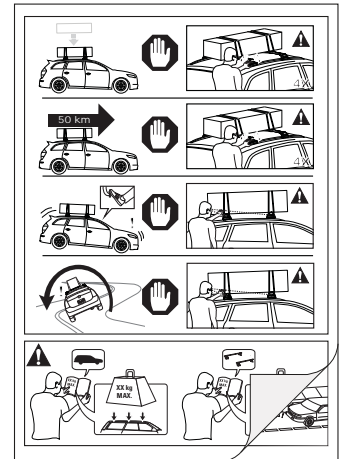

Yakima Australia Pty Ltd
17 Hinkler Court, Brendale
QLD 4500, Australia
1800 143 548
www.prorack.com.au
www.whispbar.com.au

Yakima Europe Coöperatief U.A.
Archimedesbaan 25, 3439
ME Nieuwegein, The Netherlands
+31 2080 81425
www.prorackeurope.eu
www.whispbar.eu

Yakima Products, Inc.
4101 KRUSE WAY
Lake Oswego, OR. 97035 USA
888 925 4621
www.whispbar.com